

Installation and Maintenance Manual

MRW-02

Radial Winch 60.3 ST

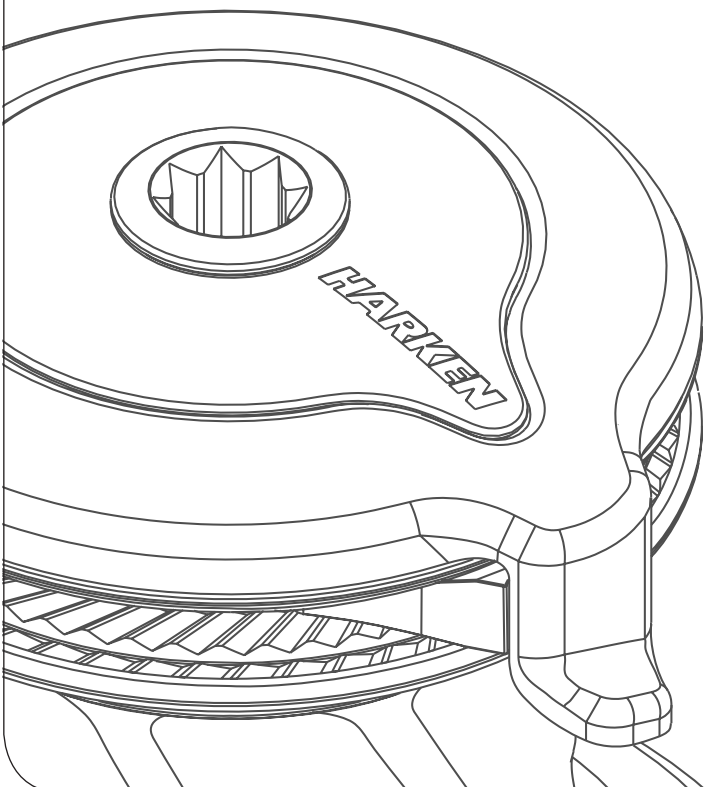

HARKEN[®]

Introduction	3
Technical characteristics	3
<i>Weights</i>	3
<i>Maximum working load</i>	3
Outline	3
Installation	4
<i>Installation procedure</i>	4
<i>Positioning the self-tailing arm</i>	7
Maintenance	8
<i>Washing</i>	8
<i>Maintenance table</i>	8
<i>Disassembly procedure</i>	8
<i>Exploded view with maintenance products</i>	12
<i>Assembly</i>	13
Harken® limited worldwide warranty	14
Ordering spare parts	14
Exploded view	15
Parts List	19
<i>Radial Winch 60.3 STA</i>	19
<i>Radial Winch 60.3 STC</i>	20
<i>Radial Winch 60.3 STCW</i>	21
<i>Radial Winch 60.3 STBBB</i>	22
<i>Radial Winch 60.3 STCCC</i>	23

Introduction

This manual gives technical information on winch installation and maintenance, including disassembling and reassembling.

This information is DESTINED EXCLUSIVELY for specialised personnel or expert users.

Installation, disassembling and reassembling of the winch by personnel who are not experts may cause serious damage to users and those in the vicinity of the winch.

Harken® accepts no responsibility for defective installation or reassembly of its winches.

In case of doubt the Harken® Tech Service is at your disposal at techservice@harken.it

This Manual is available only in English. If you do not fully understand the English language, do not carry out the operations described in this Manual.

Technical characteristics

	Power ratio	Gear ratio
1st speed	9,20 : 1	2,20 : 1
2nd speed	20,30 : 1	4,80 : 1
3rd speed	61,00 : 1	14,40 : 1

The theoretical power ratio does not take friction into account.

Weights

	ST A version	ST C/CW versions	ST BBB/CCC versions
Weight (Kg)	11,7	15,4	16,9

Versions: A = drum in anodised aluminium; C = drum in chrome bronze; CW = chrome/white;
BBB = all bronze; CCC = All-Chrome bronze

Maximum working load



WARNING!

The maximum working load (MWL) for the 60.3 ST Radial Winch is 1800 Kg (3968 lb)

Subjecting the winch to loads above the maximum working load can cause the winch to fail or pull off the deck suddenly and unexpectedly during high loads causing severe injury or death.

Outline

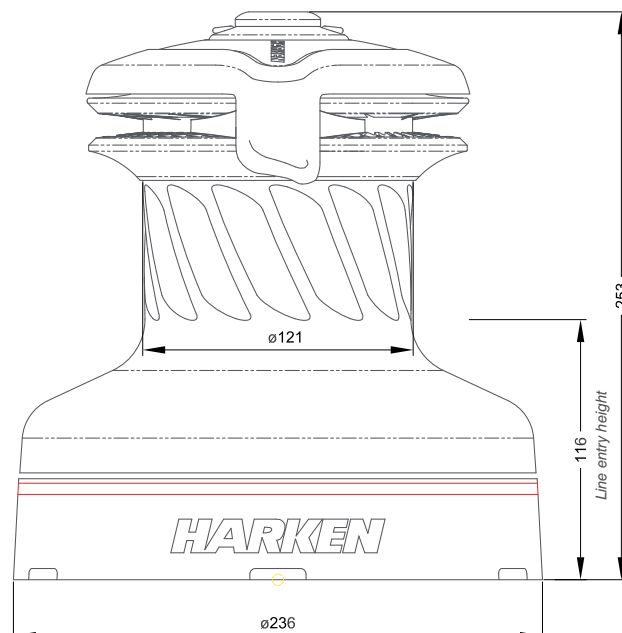

Installation

The winch must be installed on a flat area of the deck, reinforced if necessary to bear a load equal to at least twice the maximum working load of the winch.

It is the installer's responsibility to carry out all structural tests needed to ensure that the deck can bear the load.

Harken® does not supply the screws needed to install the winch since these may vary depending on the deck on which it is to be installed.

It is the installer's responsibility to choose the correct screws taking account of the loads they will have to bear.

Harken® assumes no responsibility for incorrect installation of its winches or for an incorrect choice of mounting screws.



DANGER!

Incorrect installation of the winch may cause severe injury or death. Consult the yard that built the boat in the case of doubt over the correct positioning of the winch.



WARNING!

Failure to use the correct number and type of mounting fasteners or failure to ensure the correct deck strength can result in the winch pulling off the deck suddenly and unexpectedly during high loads causing severe injury or death.



WARNING!

Verify the entry angle of the sheet. This must be 8° with tolerance of ±2°, to avoid sheet overrides and damaging the winch or making the winch inoperable leading to loss of control of the boat which can lead to severe injury or death.

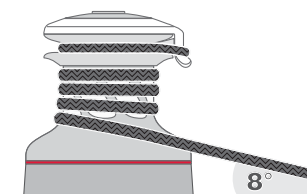

WARNING!

Mount the winch on the deck so that the drive gear is positioned where the sheet enters the winch drum. Incorrect position of drive gear can weaken winch leading to failure which can cause an accident leading to severe injury or death.

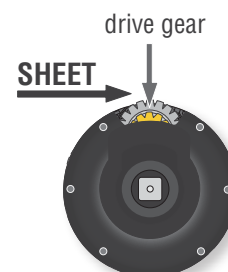

Once you have chosen the correct mounting position for the winch on the deck proceed with installation.

Installation procedure

To install the winch you must remove the drum and use Socket Head (SH) bolts.

Tools needed  One medium flat-bladed screwdriver

To identify the various parts, refer to the exploded view at the end of this Manual.

🔧 Torque to apply when assembling



1. Unscrew the central screw (🔧2Nm/18 in-lb)



2. Slide off the assy socket n°30 and the cover n°29

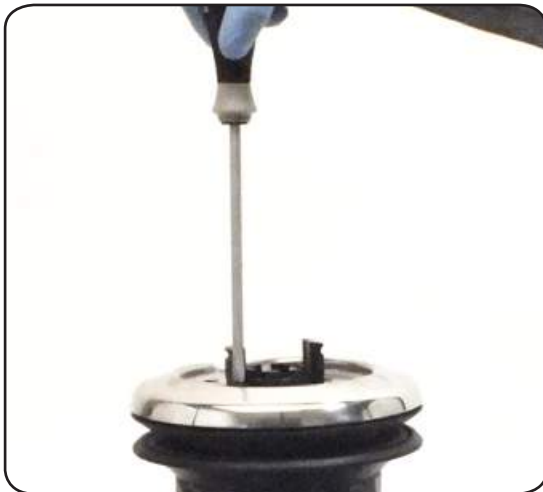

3. Unscrew the three screws n°28
(🔧4Nm/35 in-lb)



4. Remove the self-tailing arm n°27 by rotating and lifting it.



5. Lift off the drum n°24

Install the winch on the deck in the position you have chosen, keeping in mind the limits described on page 4 and using socket head (SH) bolts.

Follow steps below only to install the winch using hexagonal headed bolts



6. Remove the stripper arm housing n°21



7. Slide out the assy clutch n°37



8. Slide out the central shaft n°19



9. Unscrew the 6 hex screws n°17
($\approx 20\text{Nm}/177\text{ in-lb}$)



10. Remove the drum support n°16

Install the winch on the deck in the position you have chosen, keeping in mind the limits described on page 4 and using hexagonal headed M8 bolts.

Carry out Installation procedure then install the winch on the deck in the chosen position

A. Position the base of the winch on the deck and mark the position of the holes or use the drilling cut-out template at the point where you have decided to place the winch.

Below is a reduced scale diagram.

The drilling cut out template is available on the Harken® website, www.harken.com

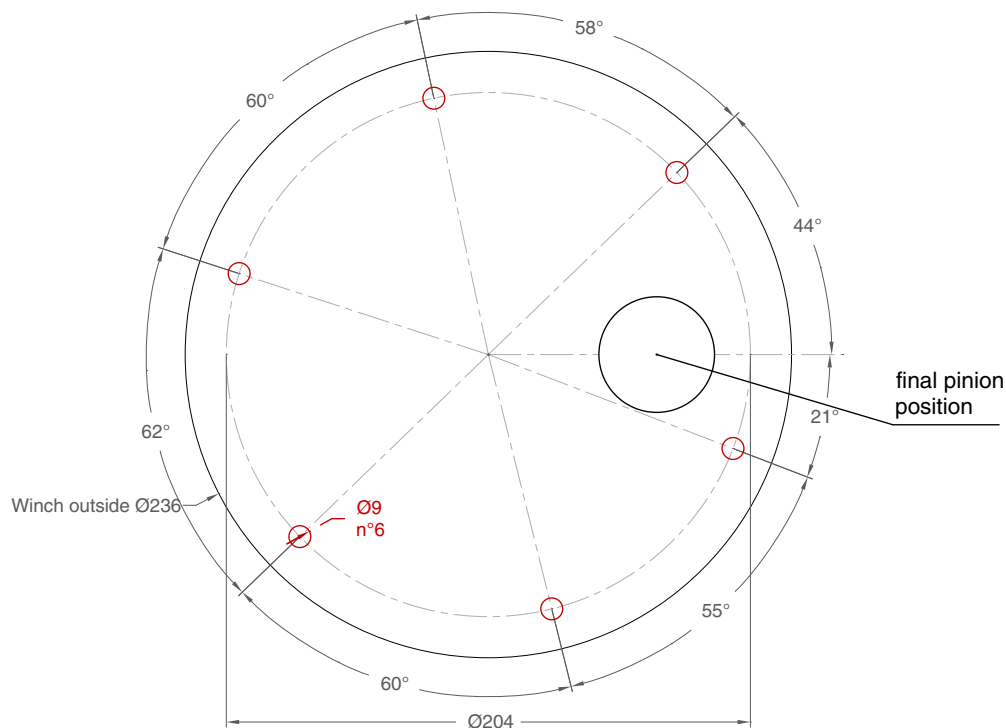

B. Remove the winch and drill the six 8.5 mm diameter holes.

C. Bolt the base of the winch to the deck using six M8 bolts (not supplied by Harken®), correctly chosen for the thickness and type of the boat deck. Consult the yard that built the boat in case of doubt.



WARNING!

To install the winch on the deck, use only bolts in A4 stainless steel (DIN 267 part11). Bolts made of other materials may not have sufficient strength or may corrode which can result in winch pulling off deck suddenly and unexpectedly during high loads causing severe injury or death.

NOTICE

To mount winches on the deck, do not use countersunk bolts.

D. Fill the mounting holes with a suitable marine sealant.

E. Remove the excess adhesive/sealant from the holes and base drainage channels

F. Reassemble the winch following the steps in Installation procedure (page 4) in the reverse order, and apply the products indicated in the section on maintenance.

NOTICE

Before closing the winch, make sure the holes and drainage channels in the base of the winch are not obstructed.

Positioning the self-tailing arm

Position the self-tailing arm so that the line leaving the winch is led into the cockpit.

Maintenance

Washing

Winches must be washed frequently with fresh water, and in any case after each use.

Do not allow teak cleaning products or other cleaners containing caustic solutions to come into contact with winches and especially anodised, chrome plated or plastic parts.

Do not use solvents, polishes or abrasive pastes on the logos or stickers on the winches. Do not use polishes or abrasive pastes on anodised, chromed plated or plastics surfaces.

Make sure that the holes and drainage channels in the base of the winch are not obstructed so that water does not collect.

Maintenance table

Winches must be visually inspected at the beginning and end of every season of sailing or racing.

In addition they must be completely overhauled, cleaned and lubricated at least every 12 months.

After an inspection, replace worn or damaged components. Do not replace or modify any part of the winch with a part that is not original.



WARNING!

Periodic maintenance must be carried out regularly. Lack of adequate maintenance shortens the life of the winch, can cause serious injury and also invalidate the winch warranty. Installation and maintenance of winches must be carried out exclusively by specialized personnel.

In the case of doubt contact Harken® Tech Service at techservice@harken.it

Disassembly procedure

Tools needed:

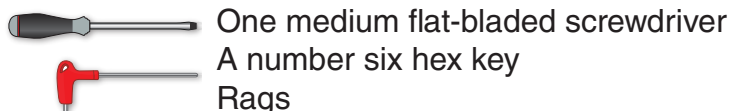

To identify the various parts refer to the exploded view at the end of this Manual.

 Torque to be applied in assembly phase

Carry out **Installation procedure** (page 4) as shown in the paragraph on winch installation and then do the following:



6. Remove the stripper arm housing n°21



7. Slide out the assy clutch n°37



8. Slide out the central shaft n°19



9. Unscrew the 6 hex screws n°17
($\approx 20\text{Nm}/177\text{ in-lb}$)



10. Slide out the drum support n°16



11. Remove the gear n°31, pawls carrier n°33, the bearings n°34 and 36 and the pin n°35
Important: washer n°7 may remain inside the drum support!



12. Remove the gear n°6, pawls carrier n°3 and the washer n°7



13. Remove the idler and pinion n°14



14. Remove the pawl carrier n°11



15. Remove gear n°10



16. Remove the gear n°2



17. Remove the roller bearing n°12



18. Remove roller bearings n°15

If it is necessary to replace any jaws of the winch, proceed as follows:



I. Unscrew the 4 screws n°26
($\approx 4\text{Nm}/35\text{ in-lb}$)



II. Remove the jaws n°23

Inspect balls inside the drum and carefully check the correct position; if it is necessary to put back any balls, push balls in the race (as shown below):



Once the winch is completely disassembled, clean the parts: use a basin of diesel oil to soak metal components and rinse plastic parts in fresh water. Once you have done this, dry the parts with cloths that do not leave residue.

Inspect gears, bearings, pins and pawls for any signs of wear or corrosion.

Carefully check the teeth of gears and ring gears to make sure there are no traces of wear.

Check the roller bearings and check there are no breaks in the bearing cages.

Replace worn or damaged components.

Carry out maintenance on components using the products listed below.

For more information on which products to use where, refer to the exploded diagram below.

Use a brush to lightly lubricate all gears, gear pins, teeth and all moving parts with grease.

Lightly lubricate the pawls and springs with oil. Do not use grease on the pawls!

Exploded view with maintenance products

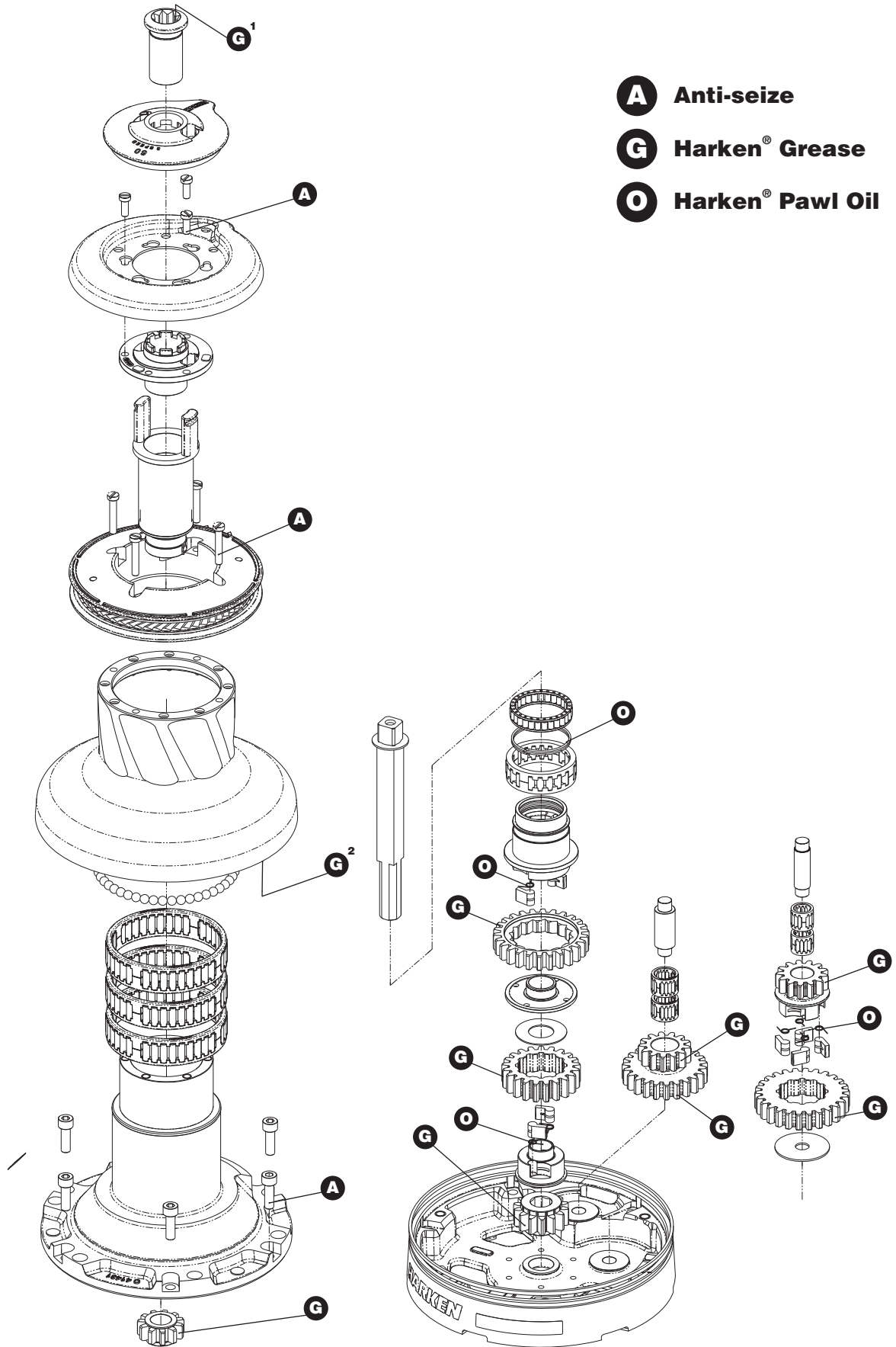

1. Apply Harken® grease on assy socket screw - 2. Apply Harken® grease on drum gear

Assembly

Make sure that the holes and drainage channels in the base of the winch are not obstructed. Assemble the winch in the reverse order of the sequence in the section on disassembly.

To tighten bolts, use the torque indicated in the disassembly procedure.



The icon ▲ on the Stripper Arm Housing indicates the Stripper Arm final position. Change the Stripper Arm Housing angle to modify the Stripper Arm final position.



When positioning the stripper arm, align the peeler with it.

If the jaws have been disassembled, insert peeler between the two jaws, taking care that the letters TOP on the peeler are facing upwards.

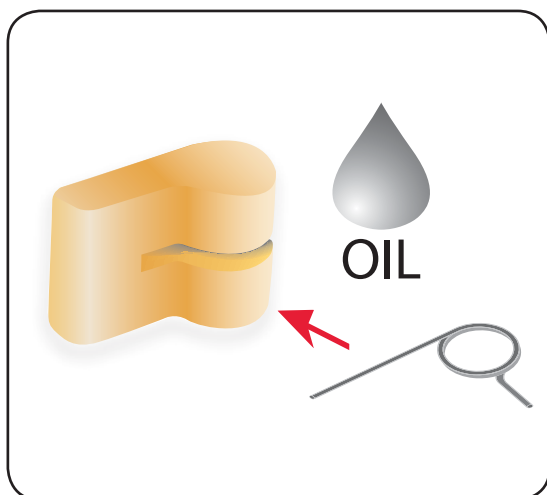

To assemble the pawls

Correctly position the spring in its housing as shown at left. Hold the spring closed and slide the pawl into its housing. Once in position, check that the pawls can be easily opened and closed with a finger.



To assemble the clutch pin

Mount the spring with the pin pointing upwards so that it is wound in an anti-clockwise direction starting from the pin.

In case of doubt concerning the assembly procedure contact Harken® Tech Service: techservice@harken.it

Harken® limited worldwide warranty

Refer to the Harken® Limited Worldwide Warranty in the Harken® Catalogue and on the website www.harken.com

Ordering spare parts

Spare parts can be requested from Harken® as described in the Harken® Limited Worldwide Warranty, indicating the part number in the Parts List and including the serial number of the winch for which the parts are required.

The serial number of the winch is printed on a plate on the drum support of the winch.



Manufacturer

Harken® Italy S.p.A.

Via Marco Biagi, 14
22070 Limido Comasco (CO) Italy
Tel: (+39) 031.3523511
Fax: (+39) 031.3520031
Email: info@harken.it
Web: www.harken.com

- **Tech Service**
Email: techservice@harken.it
- **Customer Service**
Tel: (+39) 031.3523511
Email: info@harken.it

Headquarters

Harken®, Inc.

1251 East Wisconsin Avenue
Pewaukee, Wisconsin 53072-3755 USA
Tel: (262) 691.3320
Fax: (262) 691.3008
Email: harken@harken.com
Web: www.harken.com

- **Tech Service**
Email: technicalservice@harken.com
- **Customer Service**
Tel: (262) 691-3320
Email: customerservice@harken.com

Exploded view

Radial Winch 60.3 STA, STC, STCW

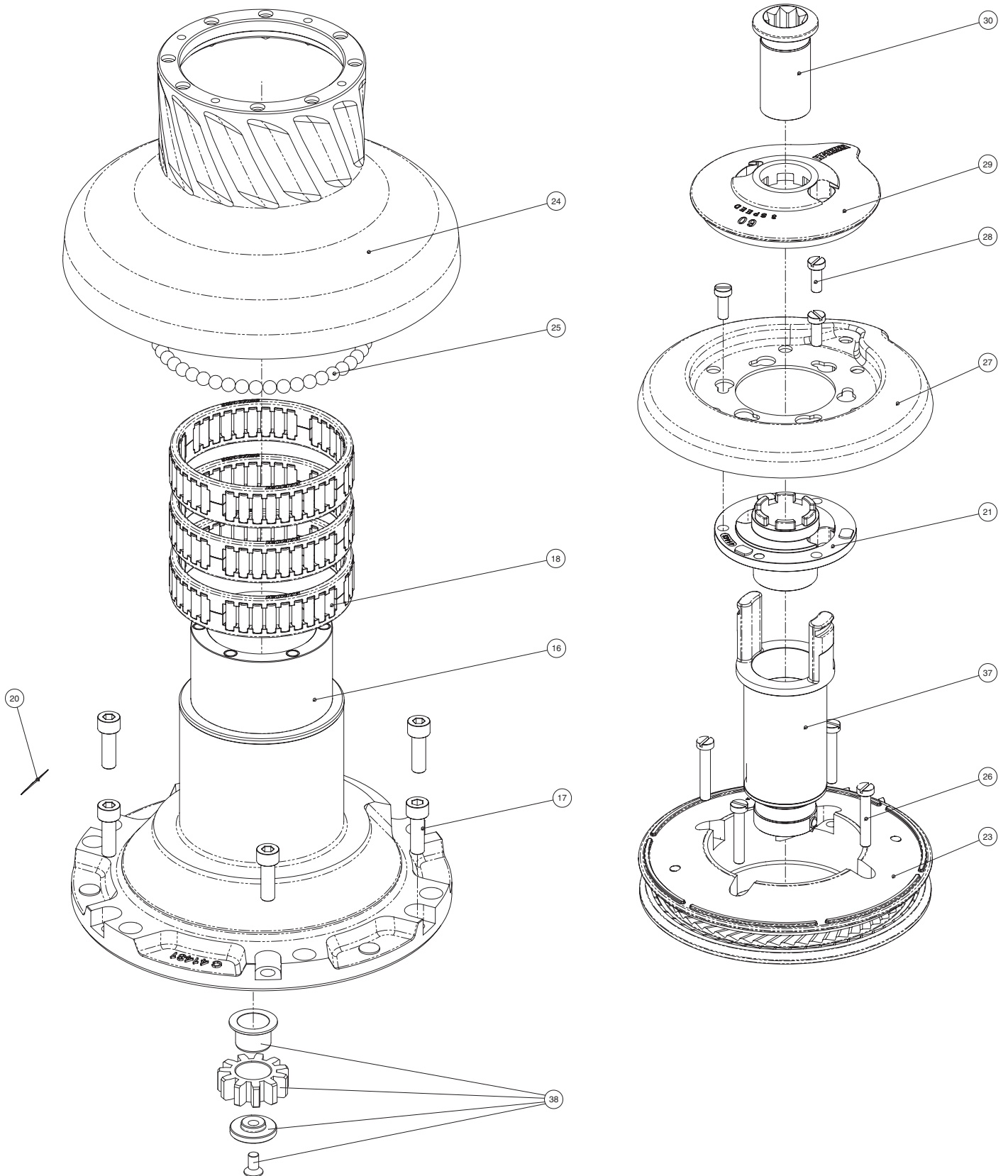

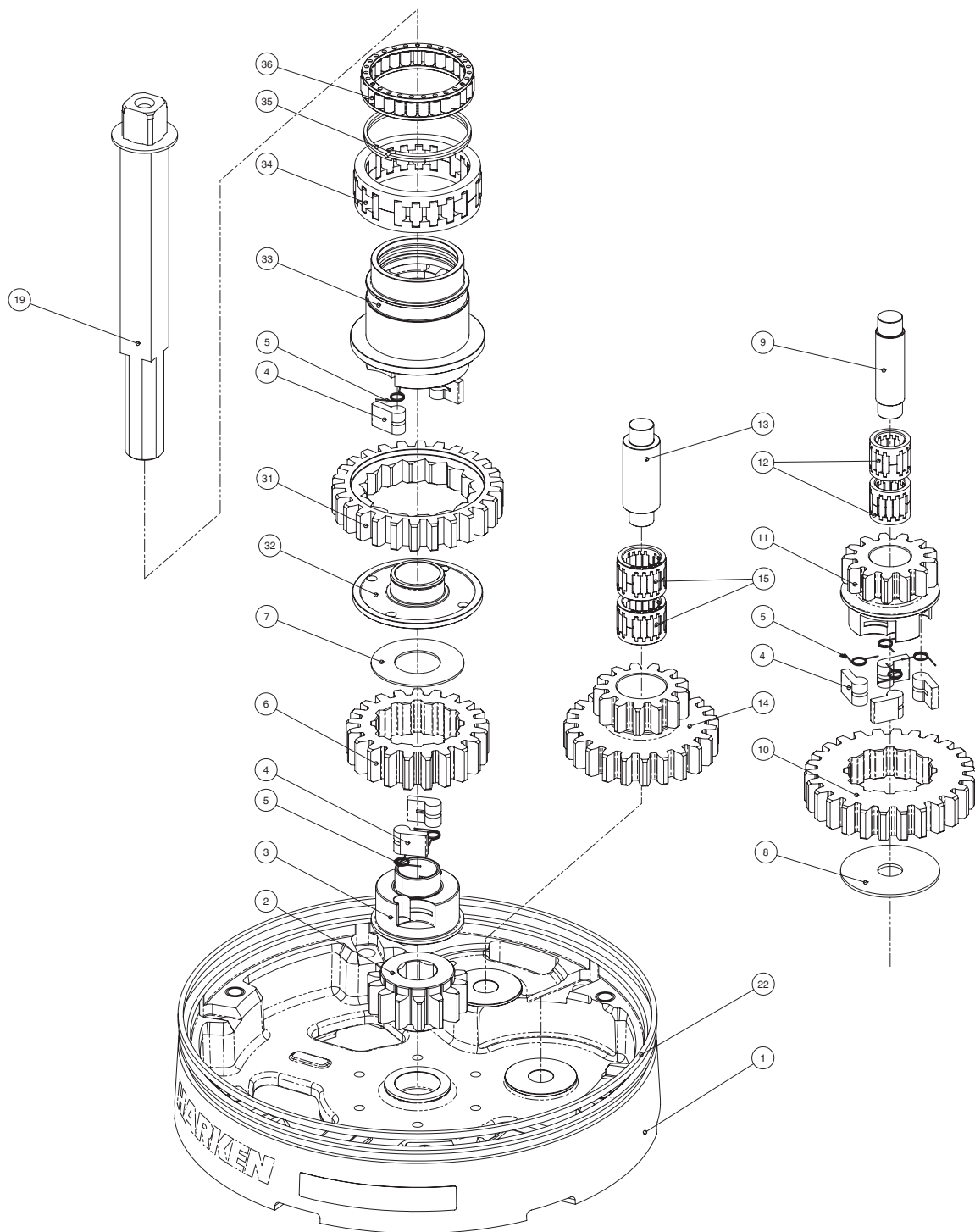
Radial Winch 60.3 STA, STC, STCW

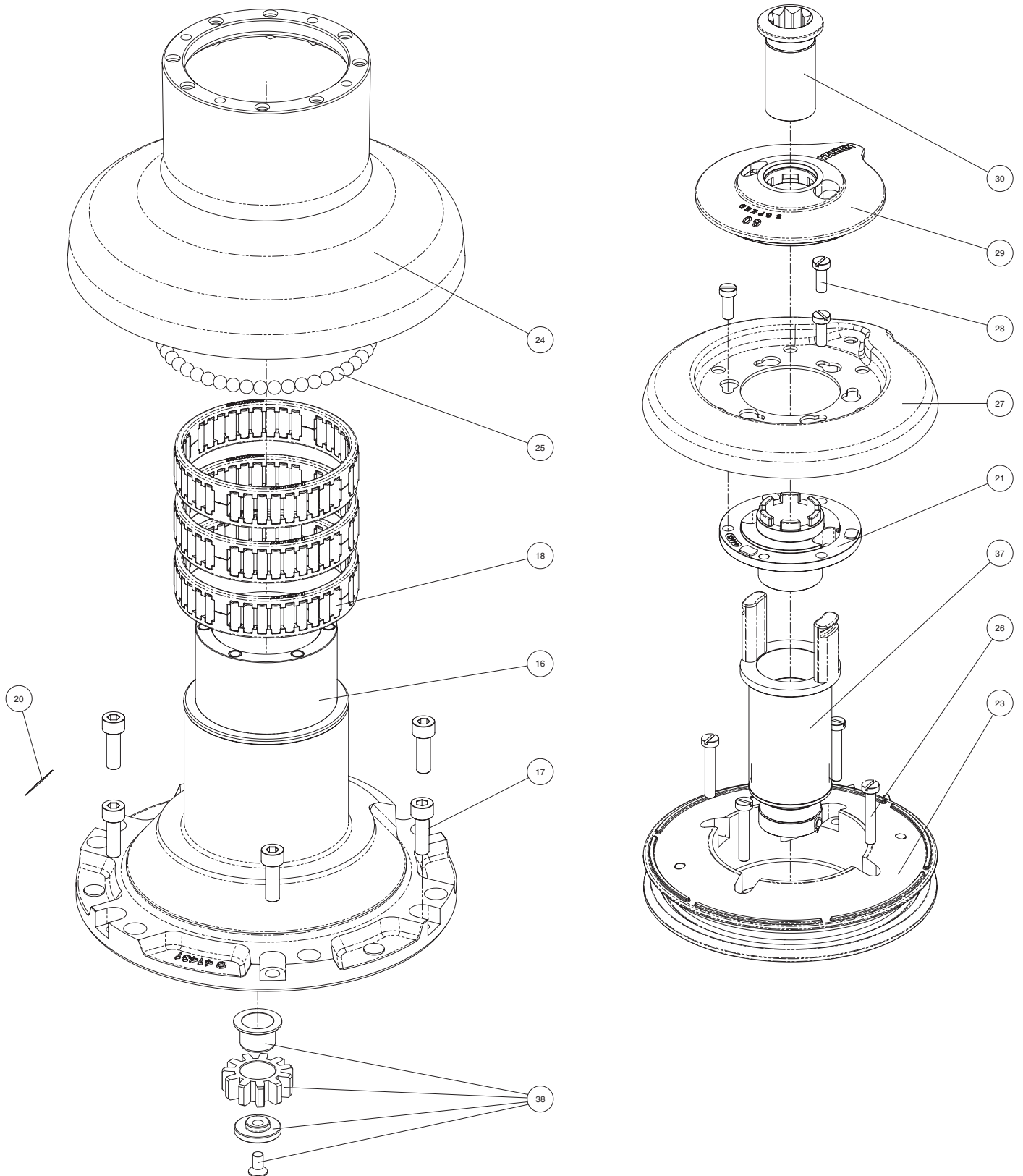
Radial Winch 60.3 STBBB, STCCC

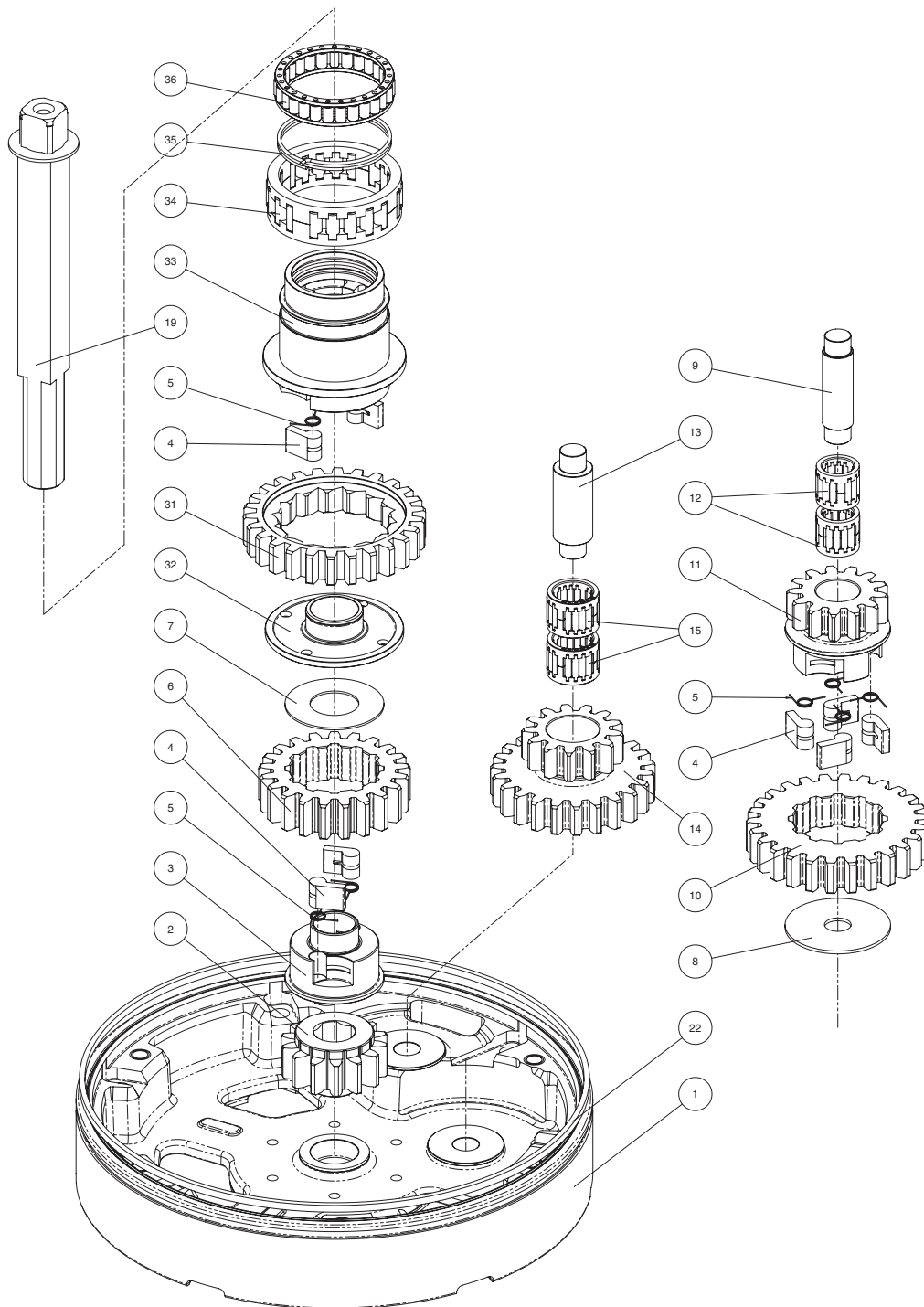
Radial Winch 60.3 STBBB, STCCC

Parts List

Radial Winch 60.3 STA

A= drum in anodised aluminium

Pos.	Q.ty	Code	Description	Pos.	Q.ty	Code	Description
1	1	A94143000	Assy Base Winch 60 <i>Base W60 Heli-coil M8x10</i>	22	1	S281700097	Red line
	1	S476030004	<i>Centering bushing Ø12</i>	23	1	A94143500	Assy Jaws Winch 60 <i>Lower Jaw W60 Upper Jaw W60</i>
	1	S4152300A7	<i>Bushing Ø22xØ25x9.5</i>				
	2	S415580085	<i>Bushing Ø12xØ35x9 Winch Product Sticker**</i>	4	S385970001	SPRING	
2	1	S414400004	Gear Z14 W60				24
3	1	S413030004	Pawls Carrier Ø8xN2	25	47	M0610280	Ball 5/16"
4	8	S000080003	Pawl Ø8*	26	4	M0601803	Screw UNI EN ISO 1207:1996 - M6x35 - A4
5	8	S000380001	Pawl Spring Ø8*	27	1	S414460019	Stripper arm Winch 60
6	1	S414390041	Ratchet Gear Z21xN2	28	3	M0601903	Screw M6x16 UNI1207
7	1	S413120002	Washer Ø22.5xØ45x1	29	1	S4167500B1	Cover 3 Speed W60
8	1	S278170002	Washer Ø12.5xØ48x1.5	30	1	A94154700	Assy Socket 3speed <i>Socket Handle 3 speed Washer Ø7.7xØ25x5.8 Screw M8x20 UNI 6109</i>
9	1	S281010004	Pin for gear				
10	1	S414420041	Ratchet Gear Z26xN4	31	1	S415130085	Gear 1V
11	1	S414410004	Pawls Carrier Gear Z13 N4	32	1	M0614303	
12	2	A72821800	Roller Bearing 14/20/18	33	1	S415400004	Shim Bushing 3 speed
13	1	S416030004	Gear Pin Ø12xØ18x52,5	34	1	A73129200	Pawls Carrier 3 speed
14	1	S414480004	Idler and Pinion Z23/Z13 W60	35	1	S377510001	ROLLER BEARING 50-62-20 ERTA P
15	2	A74162300	Roll bearing Ø24xØ18x18	36	1	A73422600	Clutch Spring
				37	1	A94158000	Bearing Ø45xØ55x12
				1	S415810081	Assy Housing Winch 60.3 <i>Housing W60 Bushing Ø12xØ35x9 Heli-coil M6x9 Bushing</i>	1
2	M6009463						
17	6	M0606303	Screw M8x25 UNI 5931	38	1	A94145300	Assy Gear 3rd speed <i>Idler Gear 3 speed Bushing Ø22/Ø25x15.5 Washer 3 speed Screw M6x12 UNI 5933</i>
18	3	A74145000	Roller Bearing Ø95xØ107x26				
19	1	A94143800	Assy Shaft Winch 60 <i>Central shaft W60 ST</i>				
	1	S413880002	<i>Washer Ø17.2xØ32x1.5</i>				
20			Winch Serial Number Sticker				
21	1	S4155700A0	Stripper arm support				

*Available with service kit; see website www.harken.com

**Winch product sticker



Radial Winch 60.3 STC

C=drum in chrome bronze

Pos.	Q.ty	Code	Description	Pos.	Q.ty	Code	Description
1	1	A94143000	Assy Base Winch 60 <i>Base W60</i>	22	1	S281700097	Red line
			<i>Heli-coil M8x10</i>	23	1	A94143500	Assy Jaws Winch 60
	1	S476030004	<i>Centering bushing Ø12</i>				<i>Lower Jaw W60</i>
	1	S4152300A7	<i>Bushing Ø22xØ25x9.5</i>				<i>Upper Jaw W60</i>
	2	S415580085	<i>Bushing Ø12xØ35x9</i>	1	1	S414850080	<i>Peeler W60 - 70</i>
			<i>Winch Product Sticker**</i>	4	4	S385970001	<i>SPRING</i>
2	1	S414400004	Gear Z14 W60	24	1	A74143400	Drum Assembly W60 C
3	1	S413030004	Pawls Carrier Ø8xN2	25	47	M0610280	Ball 5/16"
4	8	S000080003	Pawl Ø8*	26	4	M0601803	Screw UNI EN ISO 1207:1996 - M6x35 - A4
5	8	S000380001	Pawl Spring Ø8*	27	1	S414460019	Stripper arm Winch 60
6	1	S414390041	Ratchet Gear Z21xN2	28	3	M0601903	Screw M6x16 UNI1207
7	1	S413120002	Washer Ø22.5xØ45x1	29	1	S4167500B1	Cover 3 Speed W60
8	1	S278170002	Washer Ø12.5xØ48x1.5	30	1	A94154700	Assy Socket 3speed
9	1	S281010004	Pin for gear				<i>Socket Handle 3 speed</i>
10	1	S414420041	Ratchet Gear Z26xN4		1	S415130085	<i>Washer Ø7.7xØ25x5.8</i>
11	1	S414410004	Pawls Carrier Gear Z13 N4		1	M0614303	<i>Screw M8x20 UNI 6109</i>
12	2	A72821800	Roller Bearing 14/20/18	31	1	S280870041	Gear 1V
13	1	S416030004	Gear Pin Ø12xØ18x52,5	32	1	S414580081	Shim Bushing 3 speed
14	1	S414480004	Idler and Pinion Z23/Z13 W60	33	1	S415400004	Pawls Carrier 3 speed
15	2	A74162300	Roll bearing 24x18x18	34	1	A73129200	ROLLER BEARING 50-62-20 ERTA P
16	1	A94190800	Assy Housing Winch 60.3	35	1	S377510001	Clutch Spring
			<i>Housing W60</i>	36	1	A73422600	Bearing Ø45xØ55x12
	2	S415580085	<i>Bushing Ø12xØ35x9</i>	37	1	A94158000	Assy Clutch 3rd speed W60
			<i>Heli-coil M6x9</i>				<i>Assy Command tube W60</i>
	1	S415810081	<i>Bushing</i>	1	1	S415420004	<i>Dog Clutch 3 speed</i>
17	6	M0606303	Screw M8x25 UNI 5931	2	2	M6009463	<i>Spring loaded ball plunger Ø6</i>
18	3	A74145000	Roller Bearing Ø95xØ107x26	38	1	A94145300	Assy Gear 3rd speed
19	1	A94143800	Assy Shaft Winch 60		1	S414530004	<i>Idler Gear 3 speed</i>
			<i>Central shaft W60 ST</i>		1	S414550081	<i>Bushing Ø22/Ø25x15.5</i>
	1	S413880002	<i>Washer Ø17.2xØ32x1.5</i>		1	S414540080	<i>Washer 3 speed</i>
20			Winch Serial Number Sticker		1	M0604003	<i>Screw M6x12 UNI 5933</i>
21	1	S4155700A0	Stripper arm support				

*Available with service kit; see website www.harken.com

**Winch product sticker



Radial Winch 60.3 STCW

CW = chrome/white

Pos.	Q.ty	Code	Description	Pos.	Q.ty	Code	Description
1	1	A96726000W	Base Assy W60 STC W <i>Base W60 Heli-coil M8x10 Skirt W60 RAL9003</i>	22	-	-	-
	1	S6616600A5W	<i>Centering bushing Ø12</i>	23	1	A94143500W	Assy Jaws Winch 60 <i>Lower Jaw W60 RAL9003 Upper Jaw W60 RAL9003</i>
	1	S476030004	<i>Bushing Ø22xØ25x9.5</i>		1	S414850080W	<i>Peeler W60 - 70 RAL9003</i>
	1	S4152300A7	<i>Bushing Ø12xØ35x9</i>		4	S385970001	<i>SPRING</i>
	2	S415580085	<i>Winch Product Sticker**</i>	24	1	A74143400	Drum Assembly W60 C
2	1	S414400004	Gear Z14 W60	25	47	M0610280	Ball 5/16"
3	1	S413030004	Pawls Carrier Ø8xN2	26	4	M0601803	Screw UNI EN ISO 1207:1996 - M6x35 - A4
4	8	S000080003	Pawl Ø8*	27	1	S414460019	Stripper arm Winch 60
5	8	S000380001	Pawl Spring Ø8*	28	3	M0601903	Screw M6x16 UNI1207
6	1	S414390041	Ratchet Gear Z21xN2	29	1	S4167500B1W	Cover 3 Speed W60 RAL9003
7	1	S413120002	Washer Ø22.5xØ45x1	30	1	A94154700	Assy Socket 3speed <i>Socket Handle 3 speed Washer Ø7.7xØ25x5.8</i>
8	1	S278170002	Washer Ø12.5xØ48x1.5		1	S415130085	<i>Screw M8x20 UNI 6109</i>
9	1	S281010004	Pin for gear		1	M0614303	
10	1	S414420041	Ratchet Gear Z26xN4	31	1	S280870041	Gear 1V
11	1	S414410004	Pawls Carrier Gear Z13 N4	32	1	S414580081	Shim Bushing 3 speed
12	2	A72821800	Roller Bearing 14/20/18	33	1	S415400004	Pawls Carrier 3 speed
13	1	S416030004	Gear Pin Ø12xØ18x52,5	34	1	A73129200	ROLLER BEARING 50-62-20 ERTA P
14	1	S414480004	Idler and Pinion Z23/Z13 W60	35	1	S377510001	Clutch Spring
15	2	A74162300	Roll bearing 24x18x18	36	1	A73422600	Bearing 45x55x12
16	1	A94190800	Assy Housing Winch 60.3 <i>Housing W60</i>	37	1	A94158000	Assy Clutch 3rd speed W60 <i>Assy Command tube W60</i>
	2	S415580085	<i>Bushing Ø12xØ35x9</i>		1	S415420004	<i>Dog Clutch 3 speed</i>
	1	S415810081	<i>Heli-coil M6x9</i>		2	M6009463	<i>Spring loaded ball plunger Ø6</i>
	1	S415810081	<i>Bushing</i>	38	1	A94145300	Assy Gear 3rd speed
17	6	M0606303	Screw M8x25 UNI 5931		1	S414530004	<i>Idler Gear 3 speed</i>
18	3	A74145000	Roller Bearing Ø95xØ107x26		1	S414550081	<i>Bushing Ø22/Ø25x15.5</i>
19	1	A94143800	Assy Shaft Winch 60 <i>Central shaft W60 ST</i>		1	S414540080	<i>Washer 3 Speed</i>
	1	S413880002	<i>Washer Ø17.2xØ32x1.5</i>		1	M0604003	<i>Screw M6x12 UNI 5933</i>
20			Winch Serial Number Sticker				
21	1	S4155700A0	Stripper arm support				

*Available with service kit; see website www.harken.com

**Winch product sticker



Radial Winch 60.3 STBBB

BBB = all bronze

Pos.	Q.ty	Code	Description	Pos.	Q.ty	Code	Description
1	1	A96908700	Assy Base Winch 60 BBB <i>Base W60</i> <i>Heli-coil M8x10</i>	22	1	S281700097	Red line
	1	S690870043	<i>Cover for base W60 BBB</i>	23	1	A96924100	Assy Jaws Winch 60 BBB <i>Lower Jaw W60 BBB</i> <i>Upper Jaw W60</i>
	1	S476030004	<i>Centering bushing Ø12</i>		1	S414850080	<i>Peeler W60 - 70</i>
	1	S4152300A7	<i>Bushing Ø22xØ25x9.5</i>		4	S385970001	<i>SPRING</i>
	2	S415580085	<i>Bushing Ø12xØ35x9</i> <i>Winch Product Sticker**</i>	24	1	A76923900	Drum Assembly W60 BBB
2	1	S414400004	Gear Z14 W60	25	47	M0610280	Ball 5/16"
3	1	S413030004	Pawls Carrier Ø8xN2	26	4	M0601803	Screw UNI EN ISO 1207:1996 - M6x35 - A4
4	8	S000080003	Pawl Ø8*	27	1	S692400047	Stripper arm Winch 60 BBB
5	8	S000380001	Pawl Spring Ø8*	28	3	M0601903	Screw M6x16 UNI1207
6	1	S414390041	Ratchet Gear Z21xN2	29	1	A76907300	Cover W60.3 BBB
7	1	S413120002	Washer Ø22.5xØ45x1	30	1	A94154700	Assy Socket 3speed <i>Socket Handle 3 speed</i> <i>Washer Ø7.7xØ25x5.8</i> <i>Screw M8x20 UNI 6109</i>
8	1	S278170002	Washer Ø12.5xØ48x1.5		1	S415130085	
9	1	S281010004	Pin for gear		1	M0614303	
10	1	S414420041	Ratchet Gear Z26xN4	31	1	S280870041	Gear 1V
11	1	S414410004	Pawls Carrier Gear Z13 N4	32	1	S414580081	Shim Bushing 3 speed
12	2	A72821800	Roller Bearing 14/20/18	33	1	S415400004	Pawls Carrier 3 speed
13	1	S416030004	Gear Pin Ø12xØ18x52,5	34	1	A73129200	ROLLER BEARING 50-62-20 ERTA P
14	1	S414480004	Idler and Pinion Z23/Z13 W60	35	1	S377510001	Clutch Spring
15	2	A74162300	Roll bearing 24x18x18	36	1	A73422600	Bearing 45x55x12
16	1	A94190800	Assy Housing Winch 60.3 <i>Housing W60</i>	37	1	A94158000	Assy Clutch 3rd speed W60 <i>Assy Command tube W60</i> <i>Dog Clutch 3 speed</i> <i>Spring loaded ball plunger Ø6</i>
	2	S415580085	<i>Bushing Ø12xØ35x9</i>		1	S415420004	
	1	S415810081	<i>Heli-coil M6x9</i> <i>Bushing</i>		2	M6009463	
17	6	M0606303	Screw M8x25 UNI 5931	38	1	A94145300	Assy Gear 3rd speed <i>Idler Gear 3 speed</i> <i>Bushing Ø22/Ø25x15.5</i> <i>Washer 3 Speed</i> <i>Screw M6x12 UNI 5933</i>
18	3	A74145000	Roller Bearing Ø95xØ107x26		1	S414530004	
19	1	A94143800	Assy Shaft Winch 60 <i>Central shaft W60 ST</i> <i>Washer Ø17.2xØ32x1.5</i>		1	S414550081	
	1	S413880002			1	S414540080	
20			Winch Serial Number Sticker		1	M0604003	
21	1	S4155700A0	Stripper arm support				

*Available with service kit; see website www.harken.com

**Winch product sticker



Radial Winch 60.3 STCCC

CCC = All-Chrome bronze

Pos.	Q.ty	Code	Description	Pos.	Q.ty	Code	Description
1	1	A96909100	Assy Base Winch 60 CCC <i>Base W60 Heli-coil M8x10</i>	22	1	S281700097	Red line
	1	S690910043	<i>Cover for base W60 CCC</i>	23	1	A96812200	Assy Jaws Winch 60 CCC <i>Lower Jaw W60 CCC Upper Jaw W60 RAL9003 Peeler W60 - 70 RAL9003</i>
	1	S476030004	<i>Centering bushing Ø12</i>		4	S414850080W S385970001	<i>SPRING</i>
	1	S4152300A7	<i>Bushing Ø22xØ25x9.5</i>	24	1	A74143400	Drum Assembly W60 C
	2	S415580085	<i>Bushing Ø12xØ35x9 Winch Product Sticker**</i>	25	47	M0610280	Ball 5/16"
2	1	S414400004	Gear Z14 W60	26	4	M0601803	Screw UNI EN ISO 1207:1996 - M6x35 - A4
3	1	S413030004	Pawls Carrier Ø8xN2	27	1	S414460019	Stripper arm Winch 60
4	8	S000080003	Pawl Ø8*	28	3	M0601903	Screw M6x16 UNI1207
5	8	S000380001	Pawl Spring Ø8*	29	1	A76907200	Cover W60.3 CCC
6	1	S414390041	Ratchet Gear Z21xN2	30	1	A94154700	Assy Socket 3speed <i>Socket Handle 3 speed Washer Ø7.7xØ25x5.8 Screw M8x20 UNI 6109</i>
7	1	S413120002	Washer Ø22.5xØ45x1		1	S415130085	
8	1	S278170002	Washer Ø12.5xØ48x1.5		1	M0614303	
9	1	S281010004	Pin for gear	31	1	S280870041	Gear 1V
10	1	S414420041	Ratchet Gear Z26xN4	32	1	S414580081	Shim Bushing 3 speed
11	1	S414410004	Pawls Carrier Gear Z13 N4	33	1	S415400004	Pawls Carrier 3 speed
12	2	A72821800	Roller Bearing 14/20/18	34	1	A73129200	ROLLER BEARING 50-62-20 ERTA P
13	1	S416030004	Gear Pin Ø12xØ18x52,5	35	1	S377510001	Clutch Spring
14	1	S414480004	Idler and Pinion Z23/Z13 W60	36	1	A73422600	Bearing 45x55x12
15	2	A74162300	Roll bearing 24x18x18	37	1	A94158000	Assy Clutch 3rd speed W60 <i>Assy Command tube W60 Dog Clutch 3 speed Spring loaded ball plunger Ø6</i>
16	1	A94190800	Assy Housing Winch 60.3 <i>Housing W60</i>		1	S415420004	
	2	S415580085	<i>Bushing Ø12xØ35x9 Heli-coil M6x9</i>		2	M6009463	
	1	S415810081	<i>Bushing</i>	38	1	A94145300	Assy Gear 3rd speed <i>Idler Gear 3 speed Bushing Ø22/Ø25x15.5 Washer 3 speed Screw M6x12 UNI 5933</i>
17	6	M0606303	Screw M8x25 UNI 5931		1	S414530004	
18	3	A74145000	Roller Bearing Ø95xØ107x26		1	S414550081	
19	1	A94143800	Assy Shaft Winch 60 <i>Central shaft W60 ST Washer Ø17.2xØ32x1.5</i>		1	S414540080	
	1	S413880002			1	M0604003	
20			Winch Serial Number Sticker				
21	1	S4155700A0	Stripper arm Housing				

*Available with service kit; see website www.harken.com

**Winch product sticker

