

Keep this
manual onboard !

Series / parallel switch box installation manual

For Powering 24V Thruster in 12V boat

(For 99 models or newer thrusters with 4 lead electric system)



IMPORTANT NOTICE:

This manual is to be used in addition to the regular installation manual for the Sidepower thruster.

This manual is intended for professionals only that can read and understand a wiring diagram, and does not contain all detailed work instructions for what must be done to ensure correct and safe installation



SLEIPNER MOTOR AS

P.O. Box 519
N-1612 Fredrikstad
Norway
Tel: +47 69 30 00 60
Fax: +47 69 30 00 70

www.side-power.com
sidepower@sleipner.no



Made in Norway

Note! *To achieve maximum effect, reliability and durability from your Sidepower thruster, a correct installation as per the instructions are very important. Please follow the instructions carefully, and make sure that all checkpoints are carefully controlled.*

Introduction and planning for the installation of the Sidepower series / parallel switch box.

The Sidepower series/parallel switch box have been designed to provide a safe and reliable 24V power for a 24V thruster in a 12V boat.

It has been specially designed and built to accommodate for the high current demands of an electric thruster and are available in two versions, one for the SP155TC and one for the SP220TC. The only difference between these two units are the solenoid sizes for the different amp. draw.

It is also designed so that there is no need for additional charging devices and connections, the extra battery will be automatically charged by the "original" charge feed in the boat for the standard battery (battery bank) that are being used as "Batt.1".

There are no need to install 2 special battery banks as one of the boats "standard" banks can be used as Batt.1, preferably the start battery bank as this is "always" full. The start battery bank is also preferred as there are normally no electronics that can be knocked out by a voltage drop or peak caused by all heavy electromotors such as a thruster.

NOTE ! If you have electronically controlled engines (MMC / Volvo EDC / Morse etc.) the power to these must not be taken from the same battery as you power a thruster (or any other high power electric item). The best and most easy way to solve the power feed to such sensitive and critical items is to make their powersupply a protected one (either by a small extra battery for this, or by a large condensator / diode pack). It is better, easier and less expensive to provide a separate power feed to the electronic engine controls instead of a separate battery system for the heavy users, as the electronics have a very small power demand in comparison with a thruster, windlass and the engines starter motor.

Without exceptions, Batt.2 can have no other connections other than those described in these instructions.

We advice to install the extra battery (Batt.2) and the series / parallel switch box as close to the battery (bank) used as Batt.1 as possible.

Make sure to use heavy duty power cables for all battery and thruster connections including the ones between the batteries and the series/parallel box. The minimum cable size to use is 70mm² / 000 or more if required by the length. See list in manual for the thruster you are installing.

The series/parallel switch box is splash proof but must be installed in a dry position so that it can not become submerged in water.

Observe and follow the minimum battery capacity ratings described here. The smallest rating is for the SP155 and the largest for the SP200 & SP220. Remember, these are minimum ratings, bigger is better.

Always install main power switches in the main positive cables from each battery bank so that in case of a failure or emergency, the power can be switched off. The boat owner / operator must be informed of the location of these switches and instructed to shut them off when leaving the boat.

We also advice to install fuses at each battery as described in the wiring diagrams.

The switch box works like this

When the thruster is not running: (see FIG.1)

The two batteries (battery banks) are connected in parallel so that the extra battery is being charged by the boats normal 12V charge system, the same charge system that is charging the standard Batt. 1. By this, the extra battery (Batt.2) becomes a full part of the Batt. 1 bank and thereby also increase the capacity of this.

The box is built so that you can draw the same amount current from the extra Batt.2 as the thruster draws as the solenoids have the same capacity in their inactive position as in the active position. (and basically nothing on a boat draws as much as a thruster). There is no power on the main positive lead to the thruster until the thruster is activated by the control panel.

The power to the thrusters controlsystem and panel is supplied by the series/parallel switch box, via the grey and black leads to the control side of the thrusters solenoid only. Both batteries are now at 0V - 12V

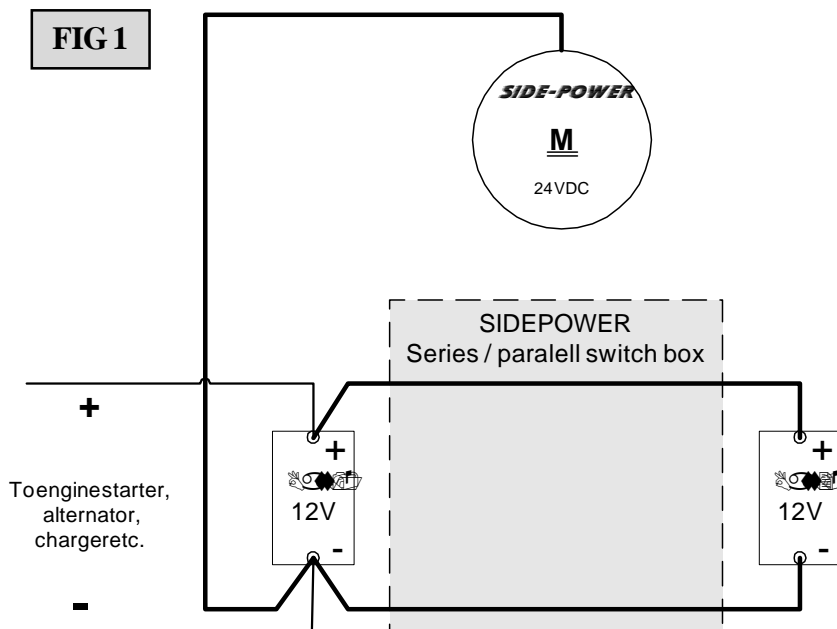

**THIS IS NOT A WIRING DIAGRAM.
Only for functional illustration.**

When you run the thruster: (see FIG.2)

When a run signal is sent to the thruster from the panel, the solenoids in the series/parallel box reacts first so that Batt.2 is moved into a series connection with Batt. 1. so that there is 24V on the main power supply cable to the thruster.

The main contactors on the thruster does not engage until this have been done so that you have 24V at the thruster to control the 24V main solenoid contactors on the thruster.

Now, only Batt.1 is being charged while Batt.2 can only draw from its own capacity.

In this position, Batt. 1 is 0 - 12V and Batt.2 becomes the 12V - 24V portion of the 24V feed to the thruster.

Batt.2 can only be connected to the series/parallel switch box as described in the manual.

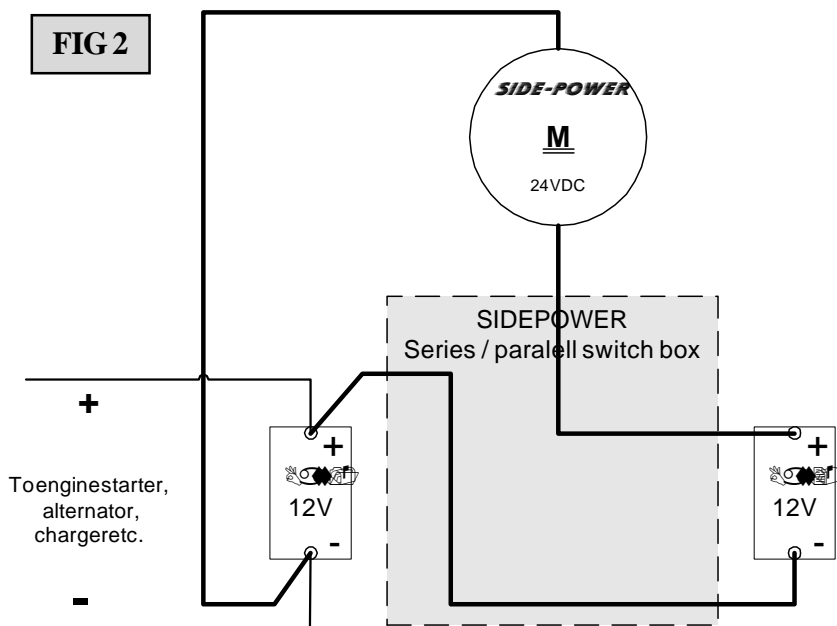

**THIS IS NOT A WIRING DIAGRAM.
Only for functional illustration.**

Installation

1. Install the thruster as per the installation instructions following it, but disregard the wiring diagram which are being replaced by the diagrams in this manual. Make sure to use the correct main cable size according to the length to thruster as listed in the thrusters manual. PS! The length measurements in this list is the total of the + and - cable.
 2. Bolt the box to a bulkhead in an accesible location as close to the two battery banks as possible. It should be positioned so that the cable openings face down .
 3. Connect the heavy main cables, main battery switches and fuses as described in the “visual” wiring diagram to the thruster, series/parallel switch box and batteries. Make sure to label all cables in both ends to ensure correct connection points. Remember to fit the rubber seals around the cables and in the box. All the connection studs in the series/parallel switch box are ø10mm . (See FIG.3 and FIG.4)
 4. Check again that the main cable wiring in the system is correct !
 5. Extend the included 2-lead wire coming out of the series/parallel switch box (grey and black) and connect these to the **lower** connectors on the thrusters main solenoid contactor. (See FIG.3 + FIG.5)
 6. Install the controlpanel(s) as per the instructions. The panels should be connected directly to the thruster as in a “normal” installation without a series/parallel switch box.
 7. If you are installing a sternthruster, make sure to follow the instructions in the sternthruster installation manual to move the electronic controlbox away from the thruster and seal the thruster compartment from general bilgewater. The electric installation of bow and stern thrusters must be treated as seperate thrusters in terms of electric wiring so that each thruster must have its own series parallel box with all the connections and a seperate Batt.2 and the 2-lead controlcable between the series parallel box and the thruster. There is an example diagram (FIG.6) on page 7. You can also use seperate battery bank 1 for each thruster, remember the 12V charge feed as described.
- NB! If you are installing both a bow and a sternthruster with series/parallel switch boxes the Batt.1 bank can be common for both thrusters providing it has the necessary capacity (minimum x 2,5) but there must be an individual Batt.2 for each thrusters. (see FIG. 6)

Minimum battery capacities

	Batt.1	Batt.2	Slow fuse / main switch rating
SP155TC	600CCA din	600CCA din	400A for 10 minutes
SP200TC	750CCA din	750CCA din	550A for 10 minutes
SP220TC	800CCA din	800CCA din	600A for 10 minutes

- CCA din is the Cold Cranking Amps rating by the DIN standard.
If your battery is rated by other standards, you should use the following factors:
DIN = SAE & BCA / 1,9 (Example: rating is 800 CCA BCA = 421 CCA DIN)
DIN = IEC / 1,3

REMEMBER: Bigger and more powerful batteries and cables will increase the thrusters performance as there will be less voltage drop to the thruster. The sizes mentioned in the manuals are the minimum sizes and the larger, the better.

FIG 3

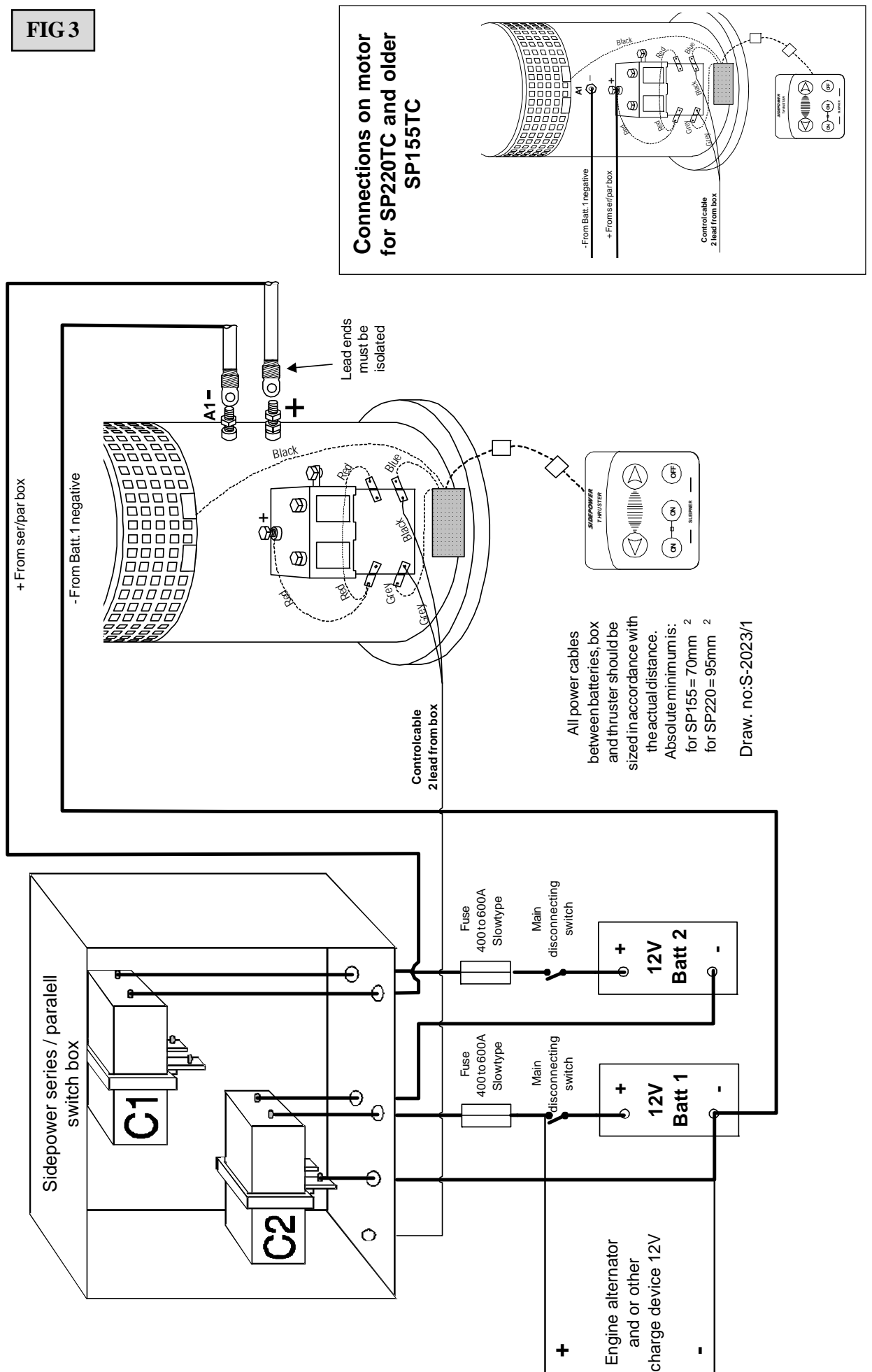

Connections on motor for SP220TC and older SP155TC

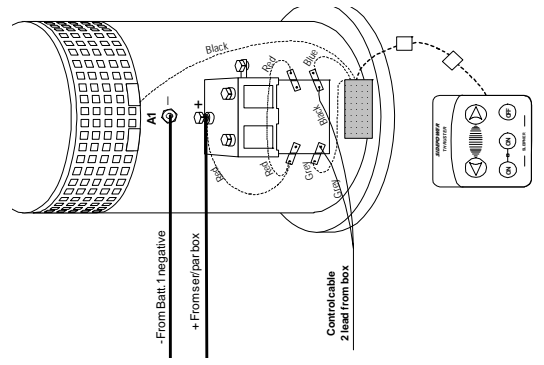

All power cables between batteries, box and thruster should be sized in accordance with the actual distance. Absolute minimum is: for SP155 = 70mm ² for SP220 = 95mm ²

Draw. no.:S-2023/1

FIG 4

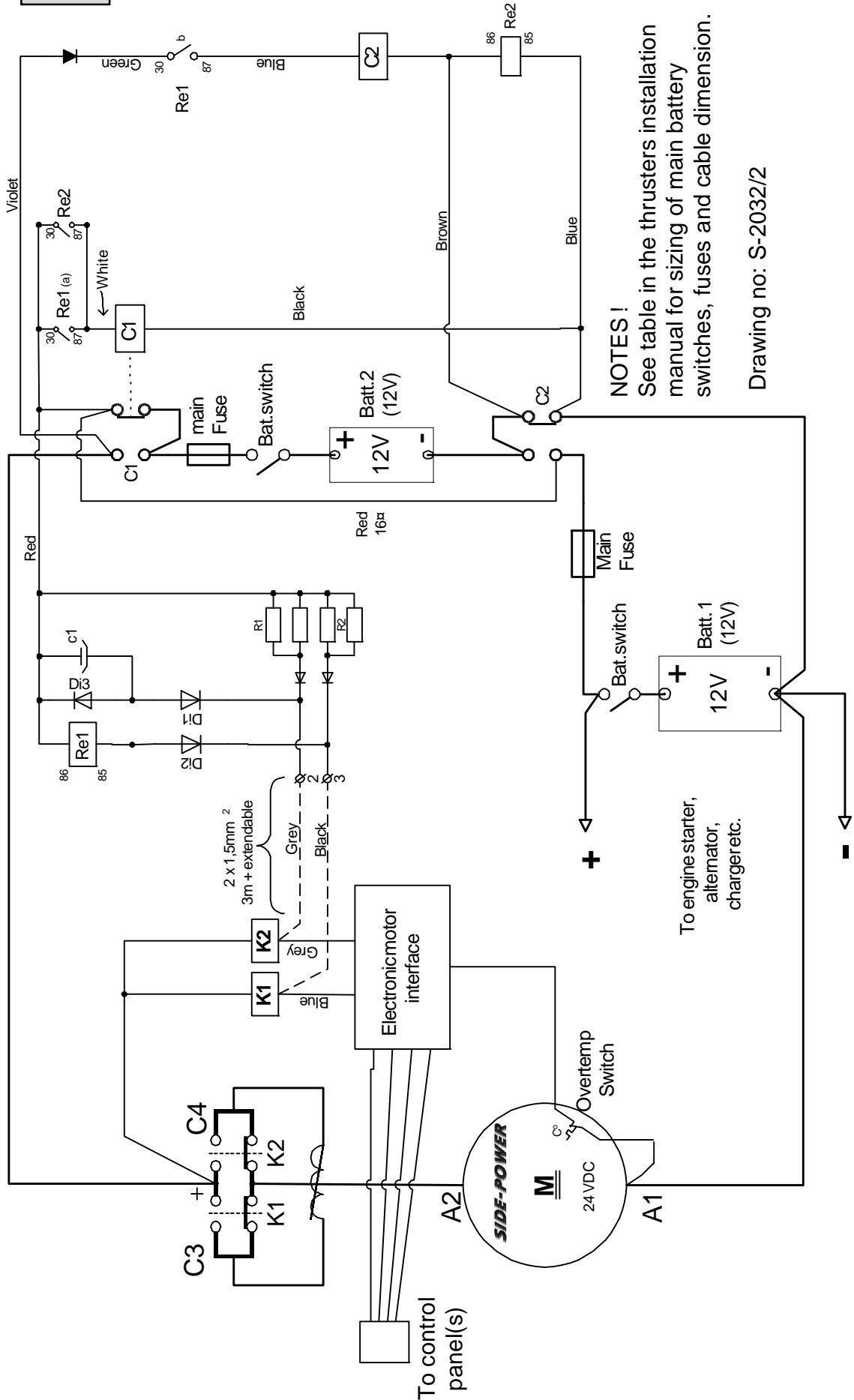

NOTES !
See table in the thrusters installation manual for sizing of main battery switches, fuses and cable dimension.

Drawing no: S-2032/2

Connection on the thrusters solenoids

FIG 5

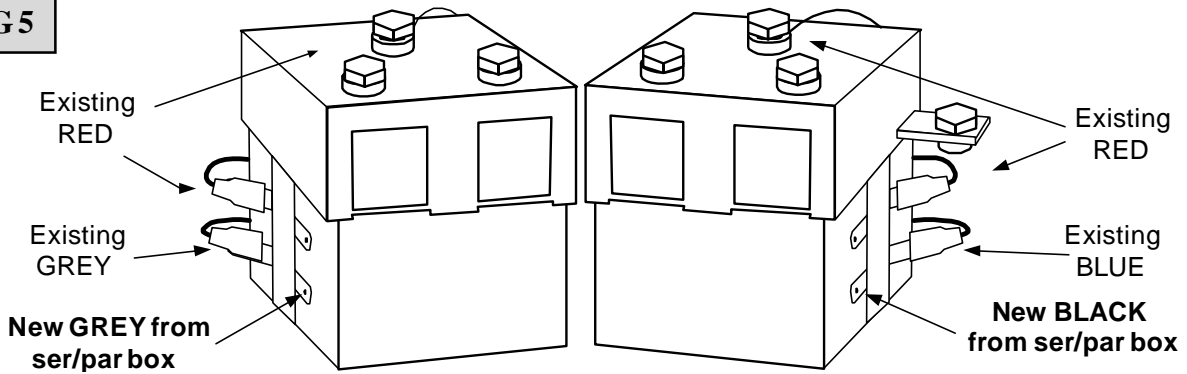

Example diagram if bow + stern thruster

FIG 6

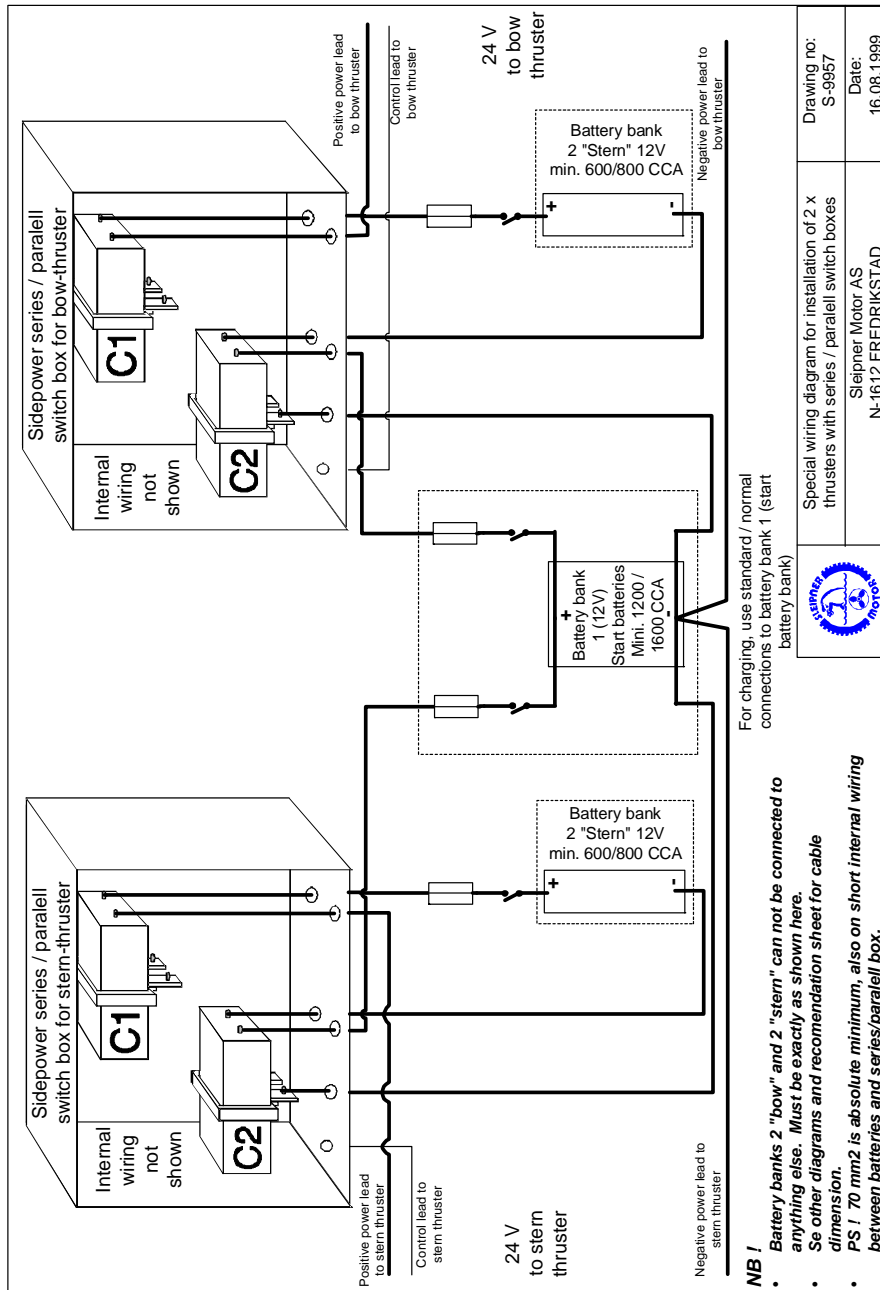

	Drawing no:	S-9957
	Date:	16.08.1999
Special wiring diagram for installation of 2 x thrusters with series / parallel switch boxes Sleipner Motor AS N-1612 FREDRIKSTAD		

Argentina

Trimer SA
Buenos Aires
Tel: +54 11 4580 0444
Fax: +54 11 4580 0440
www.trimer.com.ar
trimer@trimer.com.ar

Australia

AMI Sales
Freemantle, WA
Tel: +61 89 337 3266
Fax: +61 89 314 2929
ami@amisales.com.au

Austria

DAWA Ges.m.b.H.
Mauthausen
Tel: +43 7238 2717 0
Fax: +43 7238 2717 60

Benelux

ASA Boot Electro
Watergang
Tel: +31 20 436 9100
Fax: +31 20 436 9109
www.asabootelectro.nl
info@asabootelectro.nl

Canada

Chimo Marine Co. Ltd.
Vancouver
Tel: +1 604 253 4125
Fax: +1 604 253 3679
www.chimomarine.com
chimo@chimomarine.com

Croatia

Storm Boats
Icici
Tel: +385 51 704 500
Fax: +385 51 704 600

Denmark

Gertsen & Olufsen AS
Hørsholm
Tel: +45 4576 3600
Fax: +45 4576 1772
www.gertsen-olufsen.dk
info@gertsen-olufsen.dk

Finland

Nautikulma OY
Turku
Tel: +358 2 2503 444
Fax: +358 2 2518 470
www.nautikulma.fi
nautikulma@kolumbus.fi

France

Kent Marine Equipment
Nantes
Tel: +33 240 921 584
Fax: +33 240 921 316
www.kent-marine.com
contact@kent-marine.com

Germany

Jabsco GmbH
Norderstedt
Tel: +49 40 535 373-0
Fax: +49 40 535 373-11

Greece

Amaltheia Marine
Athens
Tel: +30 210 2588 985
Fax: +30 210 2588 986
www.amaltheiamarine.com
amalmar@otenet.gr

Iceland

Merkur HF
Reykjavik
Tel: +354 594 6000
Fax: +354 594 6001
www.merkur.is
merkur@merkur.is

Ireland

Metalcove Marine
Dublin
Tel: +353 1 668 6046
Fax: +353 1 668 6827
www.metalcove.com

Israel

Atlantis Marine Ltd.
Tel Aviv
Tel: +972 3 522 7978
Fax: +972 3 523 5150
www.atlantis-marine.com
atlantis@inter.net.il

Italy

Krautli Italia SRL.
Milano
Tel: +39 02 324 441
Fax: +39 02 392 187 05
www.krautli.it
contact@krautli.it

Japan

Global Marine Inc.
Hyogo
Tel: +81 798 347 345
Fax: +81 798 347 346
www.global-marine.co.jp
info@global-marine.co.jp

Malta

S & D Yachts Ltd.
Cali
Tel: +356 21 339 908
Fax: +356 21 332 259
www.sdyachts.com
info@sdyachts.com

New Zealand

Lusty & Blundell Ltd.
Auckland
Tel: +64 9 415 8303
Fax: +64 9 415 8304
www.lusty-blundell.co.nz
sales@lusty-blundell.co.nz

Norway

Sleipner Motor AS
Fredrikstad
Tel: +47 69 30 00 60
Fax: +47 69 30 00 70
www.side-power.com
sidepower@sleipner.no

Portugal

Krautli Portugal Lda.
Lisboa
Tel: +351 21 953 56 00
Fax: +351 21 953 56 01
www.krautli.pt
contact@krautli.pt

Spain

ZF Espana, S.A.
Madrid
Tel: +34 91 485 2695
Fax: +34 91 485 0036
www.zf-marine.com
juanma.raposo@zf.com

Sweden

Sleipner AB
Strömstad
Tel: +46 526 150 95
Fax: +46 526 152 95
www.sleipnerab.se

Switzerland

Marineparts Heimgartner
Volketswil
Tel: +41 1 997 40 90
Fax: +41 1 997 40 94
www.marineparts.ch
info@marineparts.ch

Taiwan

Mercury Marine Supply
Kaohsiung
Tel: +886 7 3317 293
Fax: +886 7 3314 232

Turkey

Denpar Ltd.
Istanbul
Tel: +90 212 285 0334
Fax: +90 212 285 0311
bilgebay@superonline.com

UK

Sleipner AB (UK)
Hayling Island
Tel: +44 2392 637 337
Fax: +44 2392 466 111
stuart@sleipner.co.uk

United Arab Emirates

Teignbridge Propulsion
Dubai
Tel: +971 4 324 0084
Fax: +971 4 324 0153
teignpro@emirates.net.ae

USA

Imtra Corporation
New Bedford, MA
Tel: +1 508 995 7000
Fax: +1 508 998 5359
www.imtra.com
sidepower@imtra.com

All other:

Sleipner Motor AS



Sleipner Motor AS
P. O. Box 519
N-1612 Fredrikstad, Norway
Tel: +47 69 30 00 60
Fax: +47 69 30 00 70

www.side-power.com
sidepower@sleipner.no