

MASTERVOLT

USERS MANUAL / GEBRUIKERSHANDLEIDING / BETRIEBSANLEITUNG
MANUEL D'UTILISATION / MANUAL DE UTILIZACION / INSTRUZIONI

MasterBus – Combi Interface

Interface between Mass Combi and MasterBus network



MASTERVOLT
Snijdersbergweg 93,
1105 AN Amsterdam
The Netherlands
Tel.: +31-20-3422100
Fax.: +31-20-6971006
www.mastervolt.com

ENGLISH

NEDERLANDS: See www.mastervolt.com/interfaces
DEUTSCH: Siehe [www.mastervolt.com/ interfaces](http://www.mastervolt.com/interfaces)
FRANÇAIS: Voir [www.mastervolt.com/ interfaces](http://www.mastervolt.com/interfaces)
CASTELLANO: Vea [www.mastervolt.com/ interfaces](http://www.mastervolt.com/interfaces)
ITALIANO: Vedere [www.mastervolt.com/ interfaces](http://www.mastervolt.com/interfaces)

TABLE OF CONTENTS:

1000009448/00 - February 2015

1 GENERAL INFORMATION..... 2

2 MASTERBUS..... 3

3 INSTALLATION 3

4 OPERATION 4

5 ORDERING INFORMATION..... 8

6 TROUBLE SHOOTING..... 9

7 TECHNICAL INFORMATION 10

8 EC DECLARATION OF CONFORMITY..... 11

1 GENERAL INFORMATION

1.1 USE OF THIS MANUAL

Copyright © 2015 Mastervolt. All rights reserved.
 Reproduction, transfer, distribution or storage of part or all of the contents in this document in any form without the prior written permission of Mastervolt is prohibited.
 This manual serves as a guideline for the safe and effective operation, maintenance and possible correction of minor malfunctions of the *MasterBus - Combi Interface*.
 This manual is valid for the following models:

Part number	Description
77030475	MasterBus - Combi Interface

Keep this manual at a secure place!

1.2 IMPORTANT TO KNOW

Incorrect installation may lead to damage to the MasterBus - Combi Interface and the connected Mastervolt devices. Be sure that all equipment is disconnected from any power source during installation.

1.3 GUARANTEE SPECIFICATIONS

Mastervolt guarantees that this product was built according to the legally applicable standards and stipulations. If you fail to act in accordance with the regulations, instructions and stipulations in this user’s manual, damage can occur and/or the product will not fulfil the specifications. This may mean that the guarantee will become null and void.

IMPORTANT: Additional warranty agreements, like “Mastervolt system warranty” may contain restrictions which forbid resetting of historical data

1.4 LIABILITY

Mastervolt can accept no liability for:

- Consequential damage resulting from the use of MasterBus - Combi Interface and/or the MasterView System software;
- Possible errors in the included manuals and the consequences of these;
- Use that is inconsistent with the purpose of the product.

2 MASTERBUS

2.1 WHAT IS MASTERBUS?



All devices that are suitable for MasterBus are marked by the MasterBus symbol.

MasterBus is a fully decentralized data network for communication between the different Mastervolt system devices. It is a CAN-bus based communication network which has proven itself as a reliable bus-system in automotive applications. MasterBus is used as power management system for all connected devices, such as the inverter, battery charger, generator and many more. This gives the possibility for communication between the connected devices, for instance to start the generator when the batteries are low.

MasterBus reduces complexity of electrical systems by using UTP patch cables. All system components are simply chained together. Therefore each device is equipped with two MasterBus data ports. When two or more devices are connected to each other through these data ports, they form a local data network, called the MasterBus. The results are a reduction of material costs as only a few electrical cables are needed and less installation time.

3 INSTALLATION

3.1 CONNECTION

What you need:

- MasterBus - Combi Interface (included)
- MasterBus cable (included, 6m)
- Serial data cable, RS 232-cross wired (included)

See figure 1

- Insert the MasterBus cables into the MasterBus data ports of the MasterBus – Combi Interface.
- Connect the Serial data cable between the MasterBus – Combi Interface and the QRS232 data port of the Mass Combi.

For central monitoring and control of the connected devices Mastervolt offers a wide range of panels which show full status information of your electrical system at a glance and a push of a button. Several panels are available, from the small MasterView Easy up to the full colour MasterView System panel. All monitoring panels can be used for monitoring, control and configuration of all connected MasterBus equipment.

New devices can be added to the existing network in a very easy way by just extending the network. Mastervolt also offers several interfaces, making even non-MasterBus devices suitable to operate in the MasterBus network

For direct communication between the MasterBus network and a product which is not from Mastervolt, the Modbus Interface is recommended.



CAUTION: Never connect a non-MasterBus device to the MasterBus network directly! This will void warranty of all MasterBus devices connected.

For information how to set up a MasterBus network refer to the manual of your MasterView display.

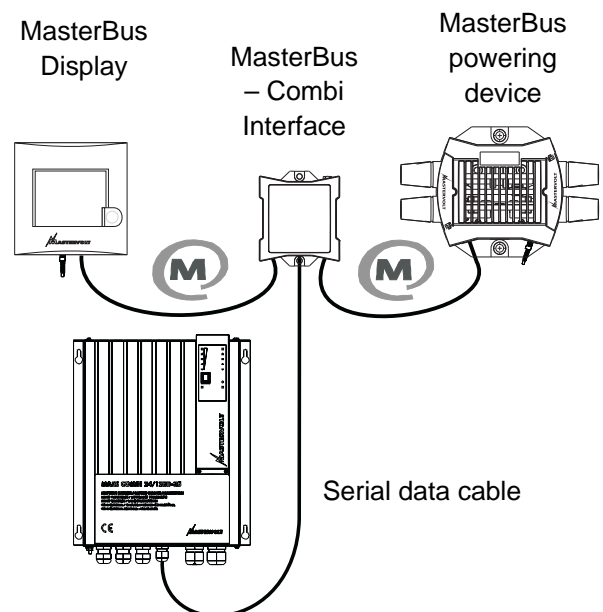

Figure 1: MasterBus - Combi Interface in system

4 OPERATION

With the MasterBus – Combi interface you can connect your Mass Combi to the MasterBus network. This enables monitoring and configuration with a MasterView display or the MasterAdjust software. This chapter offers an overview of the MasterBus functions that are available with your device.

4.1 MASTERBUS MONITORING AND CONFIGURATION OF THE MASS COMBI

4.1.1 Monitoring

Value	Meaning	Default	Adjustable range
State			
State	Shows the actual state of the Mass Combi, i.e. “Stand-by”, “Charging”, “Inverting” or “Off”. See also section 4.2.		(read only)
Mode	Shows the operation mode to which the Mass Combi is set, i.e. Auto, Chg. only, Inverter only, Standby, Off. See also section 4.2.		(read only)
Power	Function to switch on/off the Mass Combi. When “Off” is selected, MasterBus communication will remain on-line. See also section 4.2.	On	On, Off
Inverter	Function to switch on/off the Inverter part of the Mass Combi. When “Off” is selected, the Mass Combi will operate as a charger only. See also section 4.2.	On	On, Off
Charger	Function to switch on/off the Charger part of the Mass Combi. When “Off” is selected, the Mass Combi will operate as an inverter only. See also section 4.2.	On	On, Off
Shore Fuse	Limitation of the AC-input current when “Input=genset” is set to “Off”	25A	6A, 10A, 16A, 25A
Input=genset	Not shown if “Generator Load” at the Configuration menu is set to “No generator”. See section 4.1.2, <i>Power Sharing</i> . When set to “Off”, the AC-input current is limited by the “Shore Fuse” setting. When set to “On”, the AC-input current is limited by the “Generator limit” setting; see section 4.1.2, <i>Power Sharing</i>	Off	On, Off
Load	<i>Charger mode</i> : Displays the DC charge current as a percentage of the maximum current <i>Inverter mode</i> : Displays the AC power as a percentage of the nominal inverter power		(read only)
DC			
State of charger	Status of the battery charger (“Bulk”, “Absorption” “Float” or “No shore”).		(read only)
Battery	Battery voltage		(read only)
Battery	Positive value: charge current Negative value: inverter current		(read only)
AC Input			
AC Input	Voltage at the AC input of the Mass Combi		(read only)
AC Input	Input current at the AC input of the Mass Combi		(read only)
AC Output			
AC Output	AC voltage at the <i>Short Break</i> output of the Mass Combi		(read only)
AC Output	Total AC output current of the Mass Combi		(read only)

4.1.2 Configuration

Below parameters can be changed via the MasterBus network by means of a remote control panel or by means of an interface connected to a PC with MasterAdjust software. See applicable user's manuals for details.

Value	Meaning	Default	Adjustable. range
Serial interface			
Language	Language that is displayed on a monitoring device connected to the <i>MasterBus</i> .	English	English, Nederlands, Deutsch, Français, Castellano, Italiano, Norsk, Svenska
Device	Model name: "Combi"+ type designation	Model dependent	(read only)
Device name	Name of this particular device in MasterBus. This name will be recognized by all devices that are connected to the <i>MasterBus</i> network.	Mass Combi	All names with a maximum of 16 characters.
Power sharing			
Shore load	(This functionality will be implemented in a future version of the software). Must be set to "Auto".	Auto	Auto, (Manual, MPC)
Generator load	(This functionality will be implemented in a future version of the software) Must be set to "No generator" if a shore connection is used as AC source. Must be set to "Auto" if a generator is used as AC source.	No generator	No generator, Auto, (Manual, MPC)
Generator limit	Only shown when Generator load is set to "Auto". Limitation of the AC-input current when "Input=genset" is set to "On". See section 4.1.1.	25A	1-25A
Bulk			
Max. current	Maximum output current of the battery charger	I-max	0.1A – I-max
Bulk voltage	Maximum Bulk voltage	14.40/28.80/ 57.60V	8-16.00/16-32.00/ 32-64.00V
Bulk time	Minimum time that the charger stays in Bulk mode	4 min	1-255 min
Bulk return time	Delay time before charger switches to Absorption mode after reaching maximum Bulk voltage	30 sec	1-255 sec
Absorption			
Abs. voltage	Absorption voltage	14.25/28.50V/ 57.0V	8-16.00/16-32.00/ 32-64.00V
Max absorp.time	Maximum time that the charger stays in absorption mode	360 min	1-65535 min
Min absorp.time	Minimum time that the charger stays in absorption mode	45 min	0-255 min
Float			
Float voltage	Float voltage	13.25/26.50/ 53.0V	8-16.00/16-32.00/ 32-64.00V
Forced float vo.	Forced float voltage (Constant voltage charging)	13.25/26.50/ 53.0V	8-16.00/16-32.00/ 32-64.00V
Alarm			
DC Alrm high on	Alarm DC High on (see section 3.6 of the User's manual of the Mass Combi)	15.00/31.00/ 62.00V	8-16.00/16-32.00/ 32-64.00V
DC Alrm high off	Alarm DC High off (see section 3.6 of the User's manual of the Mass Combi)	14.00/28.00/ 56.00V	8-16.00/16-32.00/ 32-64.00V
DC Alrm low on	Alarm DC low on (see section 3.6 of the User's manual of the Mass Combi)	10.00/20.00/ 40.00V	8-16.00/16-32.00/ 32-64.00V
DC Alrm low off	Alarm DC low off (see section 3.6 of the User's manual of the Mass Combi)	11.00/22.00/ 44.00V	8-16.00/16-32.00/ 32-64.00V
DC Alrm delay	Alarm delay time (see section 3.6 of the User's manual of the Mass Combi)	30 sec	1-255 sec
All error	Alarm function will be triggered by all errors	Off	Off, On
Battery voltage	Alarm function will be triggered by battery voltage error	On	Off, On

Value	Meaning	Default	Adjustable. range
AC Output	Alarm function will be triggered by AC output voltage error	Off	Off, On
AC Load	Alarm function will be triggered AC output current error	Off	Off, On
Load level	Threshold value for "AC Load" error	8.7A	0.1A-25.5A
Extra			
Bulk ret. volt	Battery voltage at which charger returns to Bulk mode	12.80/25.60/ 51.20V	8-16.00/16-32.00/ 32-64.00V
Return amps	Return amps (% of maximum charge current)	6.0A/3.6A/1.8A	0.1A-25.5A
Inverter voltage	AC Output voltage of the inverter	230V	180-250V
DIP-switches			
Parallel mode	Readout of DIP switch A1 + A2: Parallel mode		(read only)
Inverter freq.	Readout of DIP switch A3: Output frequency inverter		(read only)
Energy mode	Readout of DIP switch A4 + A5: Energy saving mode		(read only)
Battery Type	Readout of DIP switch A6 + A7: Battery type		(read only)
Ground relay	Readout of DIP switch A8: Ground relay		(read only)
Power Sharing	Readout of DIP switch B1 + B2 + B3: Power sharing function		(read only)
Power support	Readout of DIP switch B4: Power Support Function		(read only)
Mains support	Readout of DIP switch B5: Generator / mains support function		(read only)
Power quality	Readout of DIP switch B6: Setting for Power Quality at incoming AC		(read only)
Equalize	Readout of DIP switch B8: Equalize mode		(read only)

4.1.3 Events

Value	Meaning	Default	Adjustable. range
Events			
Event x source	<i>Event-based command</i> Event by the Mass Combi that should result in an action by one of the other devices on the <i>MasterBus</i> network.	Disabled	(See List of event sources, section 4.1.4)
Event x target	<i>Event-based command</i> Selection of device on the <i>MasterBus</i> network that should take action due to an event by the Mass Combi.		(See Device list)
Event x command	<i>Event-based command</i> Action to be taken by the selected device.		(See <i>List of event commands</i> in the manual of the selected device.)
Event x data	<i>Event-based command</i> Value of the action to be taken by the selected device.		(See <i>List of event commands</i> in the manual of the selected device.)

4.1.4 List of events sources

Below the list of event sources of the *Mass Combi* is shown. These event sources can be used to initiate an event command and an event action at another device that is connected to the MasterBus.

Event source	Description
Disabled	(no event programmed)
Charging	The Mass Combi is in Charge mode
Inverting	The Mass Combi is in Inverter mode

4.1.5 List of event commands

Below is shown the list of event commands and event data of the *Mass Combi*. Other devices connected to the MasterBus can be programmed to initiate these commands and actions at the *Mass Combi*.

Event command	Event data	Description
Input select	On	The AC-input current will be limited by the "Generator limit" setting; see section 4.1.1, "Input Select"
	Off	The AC-input current will be limited by the "Shore Fuse" setting
	Toggle	Limitation of the AC-input current toggles between "Generator limit" and "Shore Fuse"
	Copy Invert	If the <i>Event Source</i> switches to "On", the AC-input current will be limited by the "Shore Fuse" setting; If the <i>Event Source</i> switches to "Off", the AC-input current will be limited by the "Generator limit" setting.
	Copy	If the <i>Event Source</i> switches to "On", the AC-input current will be limited by the "Generator limit" setting; If the <i>Event Source</i> switches to "Off", the AC-input current will be limited by the "Shore Fuse" setting.
Mode	On	Operation mode of the Mass Combi will be set to "Auto", see section 4.1.1, "Mode"
	Off	Operation mode of the Mass Combi will be set to "Charger".
	Toggle	Operation mode of the Mass Combi toggles between "Auto" and "Charger"
	Copy Invert	If the <i>Event Source</i> switches to "On", the Operation mode of the Mass Combi will be set to "Charger"; If the <i>Event Source</i> switches to "Off", the Operation mode of the Mass Combi will be set to "Auto".
	Copy	If the <i>Event Source</i> switches to "On", the Operation mode of the Mass Combi will be set to "Auto"; If the <i>Event Source</i> switches to "Off", the Operation mode of the Mass Combi will be set to "Charger".

4.2 OVERVIEW OF OPERATION MODES AND STATUSES

Below table shows the operation mode ("Mode") and the actual state ("State") of the Mass Combi as a result of:

- Position of the Main switch of the Mass Combi (refer to Chapter 4 of the User's manual of the Mass Combi)
- Masteradjust Monitoring setting "Power", "Inverter", and "Charger", (see section 4.1.1, *State*, of this manual)
- Availability of AC power at the AC INPUT of the Mass Combi

Position of the Main switch	Masteradjust Monitoring setting			Mode	State	
	Power	Inverter	Charger		AC input present	No AC input present
Off	—*	—*	—*	Off	Off	Off, back to default**
On	Off	—*	—*	Auto	Standby	Standby
Ch.	Off	—*	—*	Auto	Standby	Off, back to default**
On	On	Off	Off	Standby	Standby	Standby
Ch.	On	—*	Off	Standby	Standby	Off, back to default**
On	On	Off	On	Chg. only	Charging	Standby
Ch.	On	—*	On	Chg. only	Charging	Off, back to default**
On	On	On	Off	Inverter only	Standby	Inverting
Ch.	On	—*	Off	Standby	Standby	Off, back to default**
On	On	On	On	Auto	Charging	Inverting
Ch.	On	—*	On	Chg. only	Charging	Off, back to default**

Notes:

* "—" = setting is irrelevant.

** If the Main switch of the Mass Combi is in the "Ch." position while there is no AC present at the AC input or in the "Off" position:

- Communication between the Mass Combi and the MasterBus Combi interface is disabled. This also means that adjustment of the Masteradjust Monitoring settings "Power", "Inverter" and "Charger" is not possible.
- If the Main switch is set back to the "On" position again, Masteradjust Monitoring settings "Power", "Inverter" and "Charger" will be reset to their default settings (On)

5 ORDERING INFORMATION

Part number	Description
77040000*	MasterBus terminating device*
77040020	MasterBus cable (UTP patch cable), 0,2m / 0.6ft
77040050	MasterBus cable (UTP patch cable), 0,5m / 1.6ft
77040100	MasterBus cable (UTP patch cable), 1,0m / 3.3ft
77040300	MasterBus cable (UTP patch cable), 3,0m / 10ft
77040600*	MasterBus cable (UTP patch cable), 6,0m / 20ft*
77041000	MasterBus cable (UTP patch cable), 10m / 33ft
77041500	MasterBus cable (UTP patch cable), 15m / 49ft
77042500	MasterBus cable (UTP patch cable), 25m / 82ft
77050000	Set to assemble UTP patch cables: 100m / 330ft UTP cable, 50 modular jacks, crimping tool
6502001030	Serial data cable, RS 232-cross wired, 6m
6502100100	Serial data cable, RS 232-cross wired, 10m
6502100150	Serial data cable, RS 232-cross wired, 15m
6502100200	Serial data cable, RS 232-cross wired, 20m
6502100250	Serial data cable, RS 232-cross wired, 25m

* These parts are standard included with the delivery of the *MasterBus - Combi Interface*

Mastervolt can offer a wide range of products for your electrical installation, including an extended program of components for your MasterBus network. See www.mastervolt.com for a complete overview of all our products.

6 TROUBLE SHOOTING

Contact your local Mastervolt Service Centre if you cannot correct a problem with the aid of the malfunction table below. See www.mastervolt.com for an extended list of Mastervolt Service Centres.

Failure	Possible cause	What to do
No MasterBus activity is present.	There is no MasterBus powering device connected or switched on.	Connect and/ or switch on the MasterBus powering device (like the MasterShunt).
The green LED on the interface is not illuminated or blinking.	The MasterBus - Combi Interface has not been connected to the QRS232 port of the Mass Combi.	Check serial data cable and connections between the MasterBus – Combi Interface and the QRS232-port of the Mass Combi
	The MasterBus - Combi Interface has not been connected to the MasterBus port.	Check MasterBus cables and connections.
The Mass Combi is not visible on the MasterBus display.	Mass Combi is switched off.	Switch on Mass Combi
	The actual state of the Mass Combi is "Off"	See section 4.2
	Error in the wiring.	Check the serial data cable. You need Cross wired serial cables (1 to 6), no MasterBus cables.
No communication between the connected device and the MasterBus network.	If a setting of the Mass Combi has been changed, communication between the MasterBus network and the Mass Combi may take a few seconds.	Wait for a few seconds.
	The actual state of the Mass Combi is "Off"	See section 4.2
	Error in the wiring.	Check the MasterBus cables and serial cable. You need a cross wired (1 to 6) serial cable (no Straight wired cable and no MasterBus cable).
	No terminating device placed at the ends of the network.	Check if terminating devices are installed on both ends of the MasterBus network (see manual of the MasterBus powering device).
	MasterBus network is configured as a ring network.	Ring networks are not allowed (see manual of the MasterBus powering device). Check the connections of the network.
	T-connections in the MasterBus network.	Check if there are no T-connections in the network. T-connections are not allowed (see manual of the MasterBus powering device).
Wrong language is displayed.	Wrong setting of the language at the Combi Interface.	Click on the "Language" menu and select the desired language.
	Wrong setting of the language at the MasterBus display.	Each separate connected device can have its own language setting, including the display. See user's manual of the display.

7 TECHNICAL INFORMATION

7.1 SPECIFICATIONS

Model:	MasterBus – Combi Interface
Article number:	77030475
Delivery includes:	Interface, Serial data cable, MasterBus cable, MasterBus terminating device, user's manual
Function of instrument:	Communication interface between a Mastervolt Mass Combi and the MasterBus network.
Compatible with:	Mass Combi
Manufacturer:	Mastervolt Amsterdam, the Netherlands
MasterBus Powering capabilities:	Yes
Power consumption:	144 mW
Weight	Approx. 80 gr
Protection degree:	IP 21
Dimensions:	See section 7.2

7.2 DIMENSIONS AND CONNECTORS

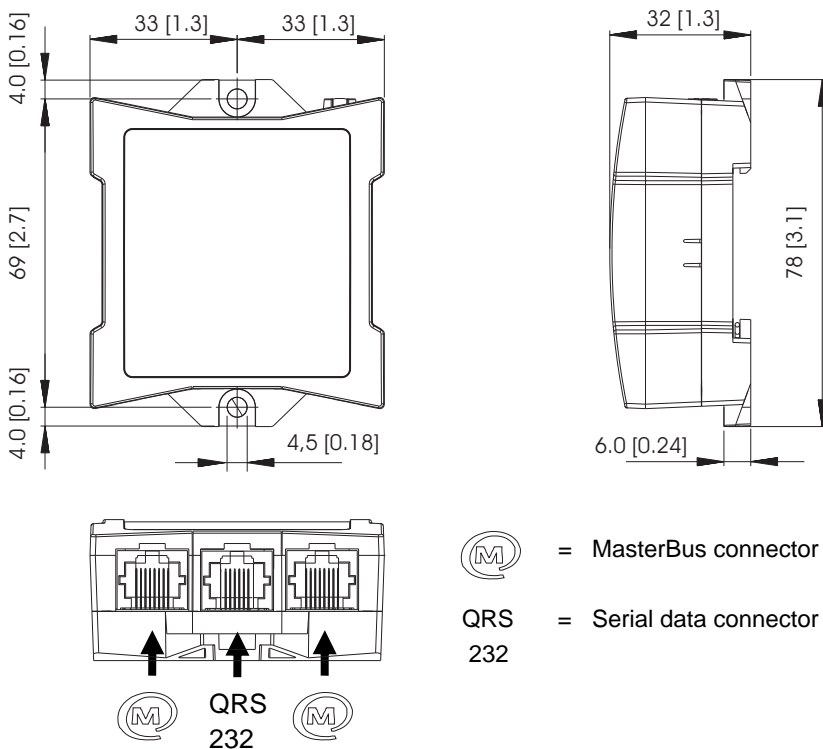

Figure 2:
Dimensions in mm (inch)
and connectors

8 EC DECLARATION OF CONFORMITY



We,
Manufacturer Mastervolt
Address Snijdersbergweg 93
 1105 AN Amsterdam
 The Netherlands

Declare under our sole responsibility that product

77030475 MasterBus – Combi Interface

Is in conformity with the provisions of the following EC directives:

2004/108/EC (EMC directive); the following harmonized standards have been applied:

- EN 61000-6-3: 2007 Emission for residential, commercial and light-industrial environments
- EN 61000-6-2: 2007 Immunity for industrial environments

2011/65/EU (RoHS directive)

Amsterdam, 21 January 2015

A handwritten signature in black ink, appearing to read 'H.A. Poppelier', is written over a light grey rectangular background.

H.A. Poppelier
Manager New Product Development

MASTERVOLT
THE POWER TO BE INDEPENDENT

Snijdersbergweg 93, 1105 AN Amsterdam, The Netherlands

Tel : + 31-20-3422100

Fax : + 31-20-6971006

Email : info@mastervolt.com