



**Marine Warehouse**  
2330 NW 102 Avenue, Suite 1  
Doral, FL 33172  
USA  
Tel: (305) 635-0776  
sales@marinewarehouse.net

## Custom Panel Drawer Units

Indel Webasto Marine's products possess a high degree of customization, allowing installations fully integrated with the on board design. A perfect integration with the on board design means harmony and elegance with the furniture present inside the boat. For this purpose IWM has introduced the Drawer 49, 55, 65 and 160 with a door ready to be customized with the client's door front.

Three brackets are included with each door which are easily mounted on the back of your custom panel. Corresponding anchor points make installing your custom panel easy, repeatable, and fast.

Following are part numbers and descriptions:



- 3049BA7P00015** Drawer 49 - Refrigerator and Freezer - AC/DC with Special Brackets for 3/4 inch wood panel front  
External Dimensions: 20.9h x 15.9w x 20.5d
- 3055BG4P00015** Drawer 55 – Frost Free Freezer - AC/DC with Special Brackets for 3/4 inch wood panel front  
External Dimensions: 20.9h x 18.5w x 21d
- 3065BA7P00015** Drawer 65 - Refrigerator and Freezer - AC/DC with Special Brackets for 3/4 inch wood panel front  
External Dimensions: 20.9h x 18.5w x 21d
- 3065BG7P00015** Drawer 65 – Frost Free Refrigerator - AC/DC with Special Brackets for 3/4 inch wood panel front  
External Dimensions: 20.9h x 18.5w x 21d  
*Call for a custom quotation 305 635 0776*
- D070DNLCP72113AA** Drawer 70 REFRIGERATOR ONLY - Custom Panel with Special Brackets for 3/4 inch wood front- AC/DC  
- Remote Mount Compressor
- D070DNLCP73113AA** Drawer 70 FREEZER ONLY - Custom Panel with Special Brackets for 3/4 inch wood front - AC/DC - Remote Mount Compressor
- D070DNLCP65113AA** Drawer 70 FREEZER WITH ICE MAKER - Custom Panel with Special Brackets for 3/4 inch wood front - AC Only 115v - Remote Mount Compressor
- D070DNLCP55113AA** Drawer 70 FREEZER WITH ICE MAKER - Custom Panel with Special Brackets for 3/4 inch wood front - AC 230v/50Hz - Remote Mount Compressor  
*Call for a custom quotation 305 635 0776*
- 3160BA7C00015** Double Drawer 160 LIGHT - REFRIGERATOR ONLY - AC/DC with Special Brackets for 3/4 inch wood panel front - External Dimensions: 34h x 24.6w x 23d
- 3160BB3C00015** Double Drawer 160 LIGHT REFRIGERATOR / FREEZER - AC/DC with Special Brackets for 3/4 inch wood front - External Dimensions: 34h x 24.6w x 23d
- 3160BC3C00015** Double Drawer 160 LIGHT FREEZER ONLY - AC/DC with Special Brackets for 3/4 inch wood panel front  
External Dimensions: 34h x 24.6w x 23d
- 3160BM6C00015** Double Drawer 160 LIGHT FRIDGE-FREEZER- ICE MAKER - AC Only (115v) with Special Brackets for 3/4 inch wood front - External Dimensions: 34h x 24.6w x 23d
- 3160BP6C00015** Double Drawer 160 LIGHT FREEZER ONLY WITH ICE MAKER - AC Only (115v) with Special Brackets for 3/4 inch wood panel front - External Dimensions: 34h x 24.6w x 23d

Marine Warehouse

Miami - Trinidad - Panama - Grenada - Tahiti - Curacao - Bonaire - Aruba - St Maarten - Colombia - Langkawi - Nuku-Hiva - Raiatea

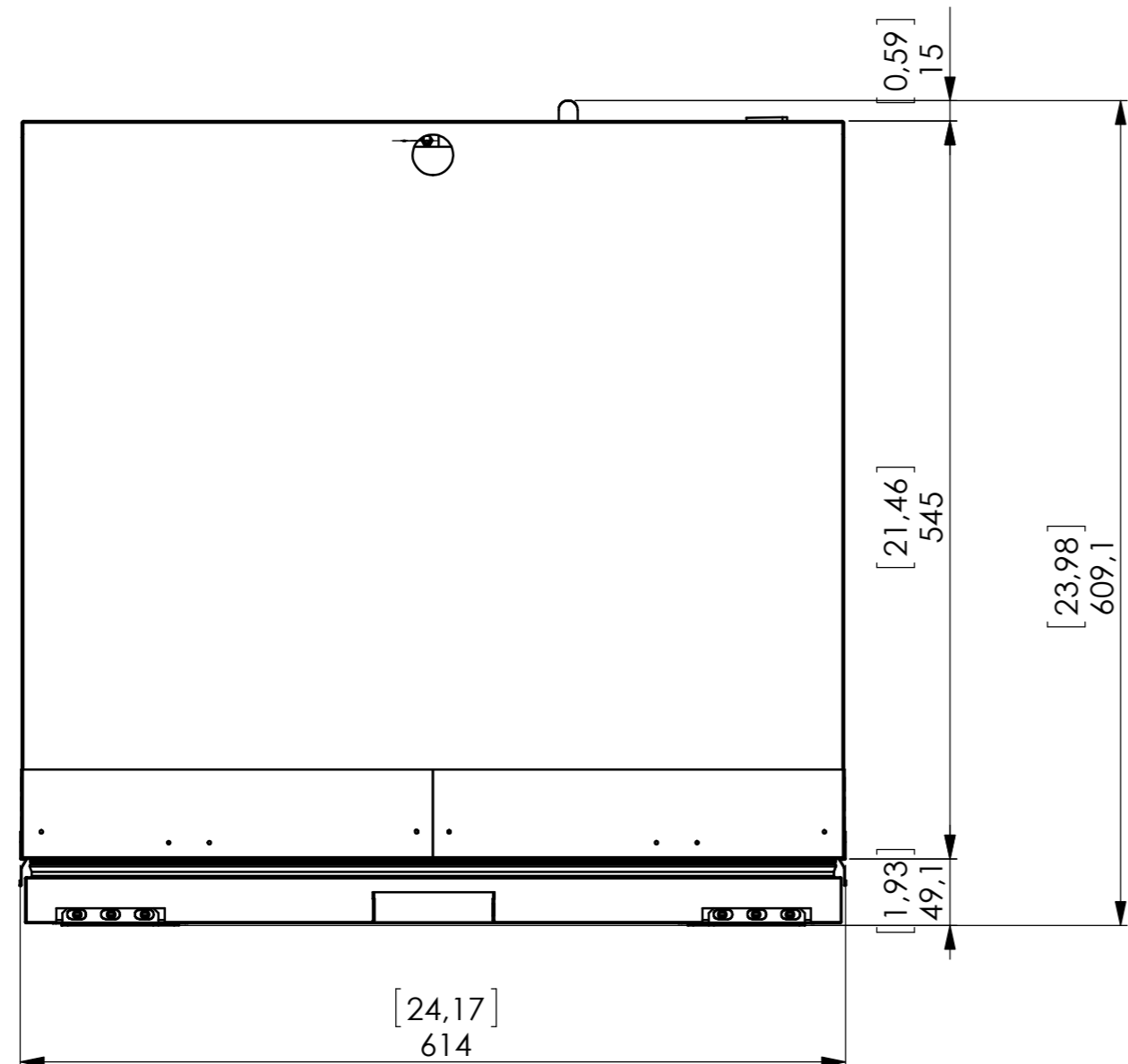
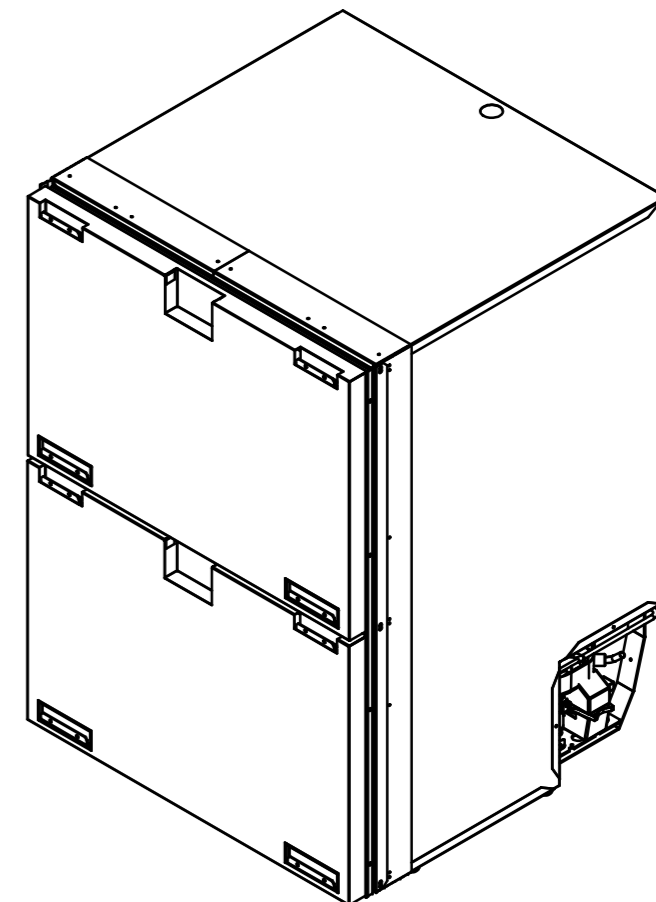
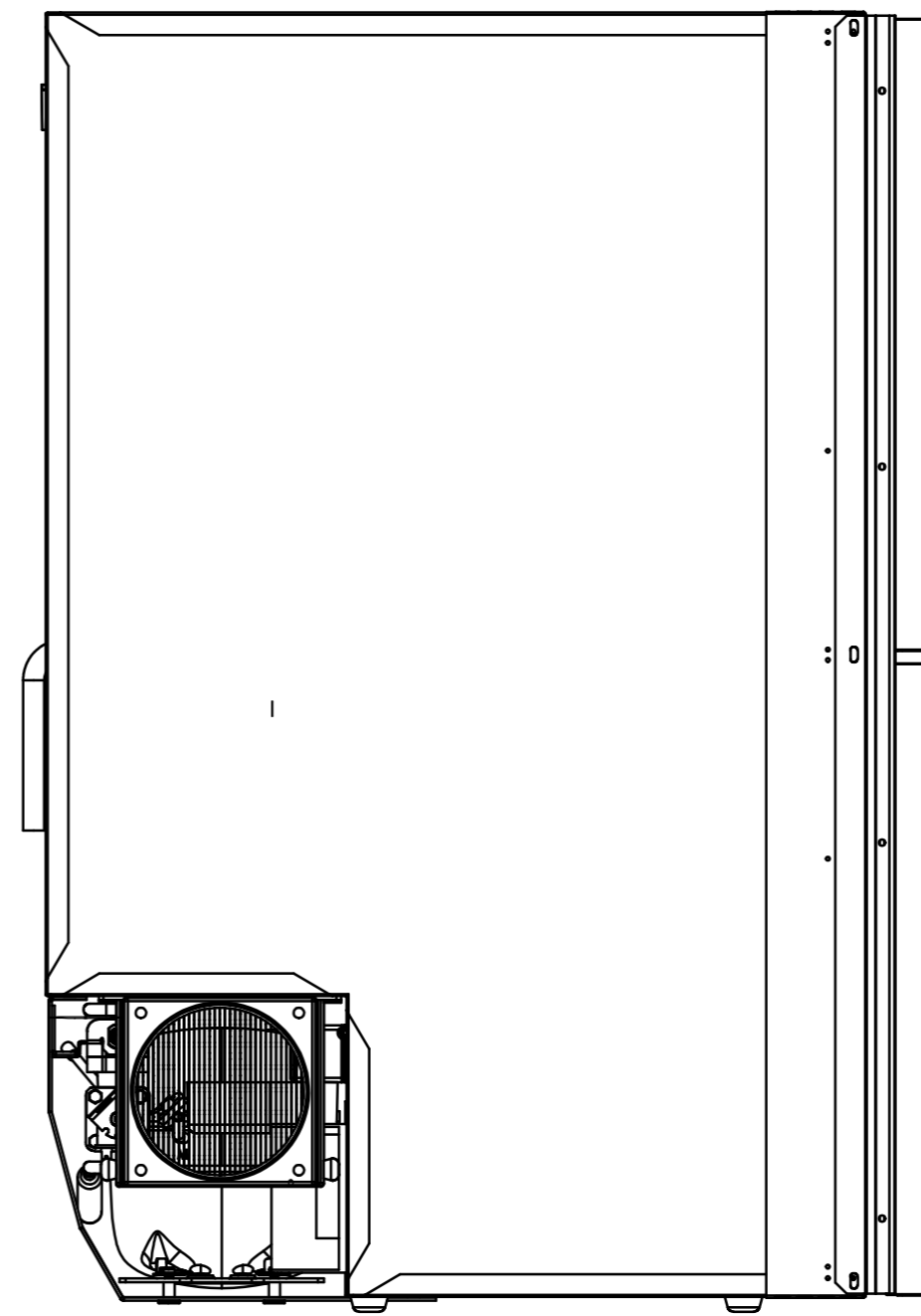
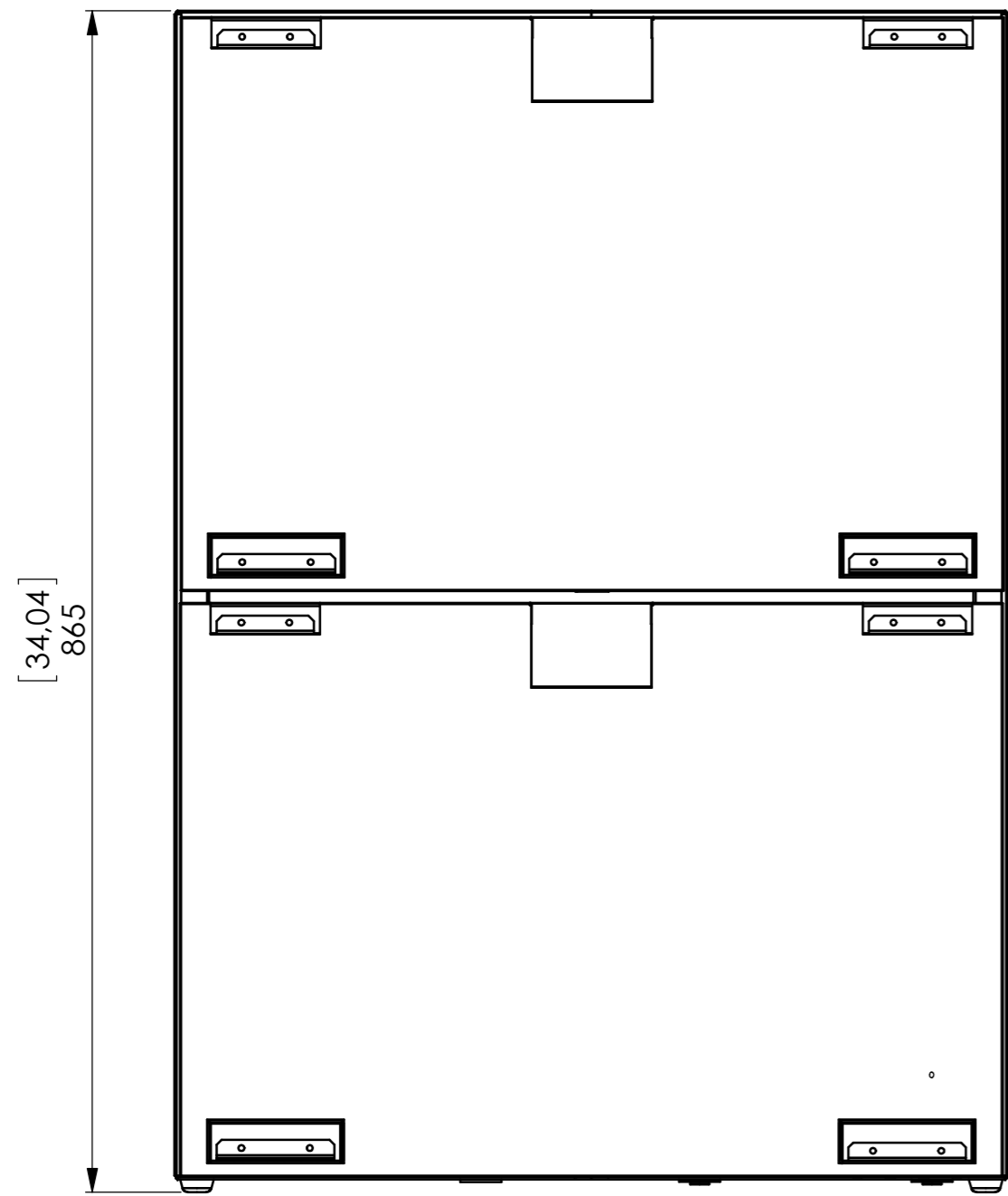

TUTTI I MATERIALI E COMPONENTI NON DEVONO CONTENERE PIOMBO, MERCURIO, CADMIO, CROMO ESAVALENTE, BIFENILI POLIBROMURATI (PBB) O ETER DI DIFENILE POLIBROMURATO (PBDE).  
(Direttiva 2002/95/CE del Parlamento Europeo e del Consiglio del 23 gennaio 2003)

CRD 160 FRIGO PANNELLABILE - CRD 160 FRIGO-FREEZER PANNELLABILE											
Pos.	DENOMINAZIONE	Q	Materiale	Stato/Unific.	Peso	Codice					
Tolleranze generali	Caratteristiche speciali da P-PRO	Disegnato	Data	Scala	Cod. provv.						
ISO 2768 - m	⚠ CRITICA ⊕ IMPORTANTE	CECCAGLIA	18/09/2012	1:5	Sost. II						
<b>indel B</b>		Loc. Cà Baldone, 47866 Sant'Agata Feltria (RN) Italy Tel. +39 0541 848 711 - Fax +39 0541 848 746				CODICE					
A termini di legge ci riserviamo la proprietà di questo disegno con divieto di riproduzione senza la nostra autorizzazione											

N° Data Dis. MODIFICHE E.C.

H

A2