



Marine Warehouse
2330 NW 102 Avenue, Suite 1
Doral, FL 33172
USA
Tel: (305) 635-0776
sales@marinewarehouse.net

Isotherm CRUISE 100 Classic - Large CRUISE Marine Refrigerator

The CR 100 differentiates itself with air ducts and fan ventilated compressor which permits circulation even in tight installations. Additional mounting frames are available as an option. It also features A freezer compartment

Your Advantages:

- Volume: 100 liters
- Available with ASU
- Mounting frames for an easy and neat installation
- Permits circulation even in tight installations
- 5L freezer compartment
- Silent, high efficient, fan cooled 12/24V Danfoss / Secop compressor (type BD35F)



Available Models:

1100BA1IA0000 - Cruise 100 Classic Refrigerator - DC Only, Right Swing, 2-sided fixing frame

1100BA7IA0000 - Cruise 100 Classic Refrigerator - AC/DC, Right Swing, 2-sided fixing frame

Technical Details:

- Type: CR 100
- Volume (cu.ft): 3.5
- Dimensions: 29.3h x 19.1w x 17.9d
- Power Consumption W/24Hr: 400
- Weight: 46 lbs.

Marine Warehouse

Miami - Trinidad - Panama - Grenada - Tahiti - Curacao - Bonaire - Aruba - St Maarten - Colombia - Langkawi - Nuku-Hiva - Raiatea

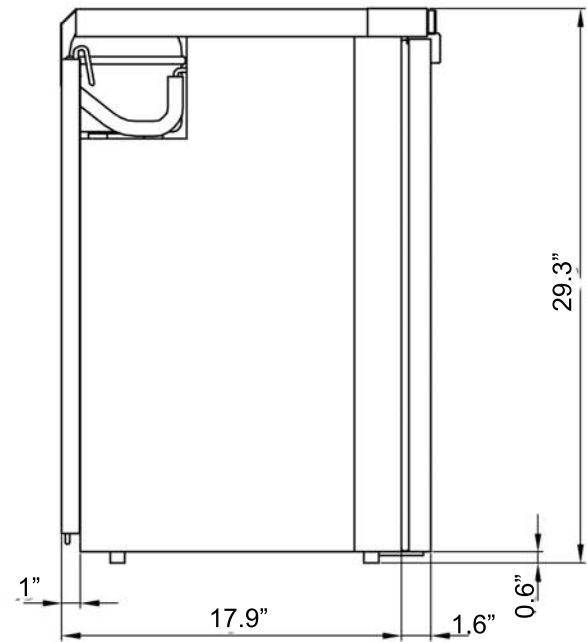
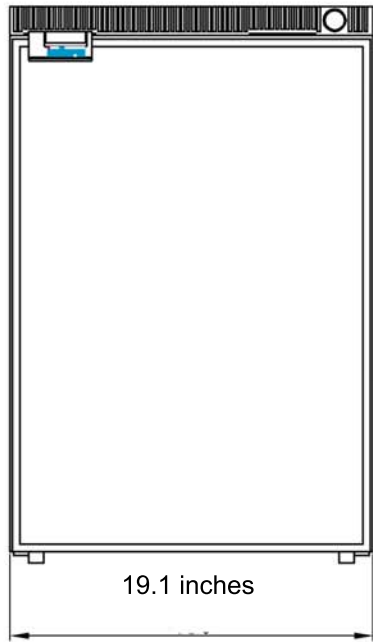

Rev/rev	Quantity	Title/Name, description, material, dimension etc			Article No./Reference	
Designed by	Checked by	Approved by - date	Fluorene	Date	961108/LLG	Scale
				Title/Name Isotherm Cruise 100		
				Drawing number	CR100	Sheet

RevNo	Revision note	Date	Signature	Checked