



Features & Benefits

Professional Series EV Advanced AGM Batteries, Designed and Engineered for Dependability in Commercial, Industrial, Public and Private applications; Mobility and Home Medical Equipment (HME), Broadband and Cable TV (CATV), Uninterruptible Power Supplies (UPS) and Telecommunication, Photovoltaic, Solar and Renewable Energy, Electronic and Security, Marine and RV, Golf and Electric Vehicle, Aerial Lifts and Fork Lifts, Floor Machines and Robotics.

- *In Doors*
- *Out Back*
- *Off Shore*
- *On Duty*

Discover™ Professional Series Batteries have the Features and Benefits that matter to your customers and you!

Advanced AGM

- Completely sealed valve regulated construction.
- Flame arresting pressure regulated safety sealing valves for safety, operating pressure management and protection against atmospheric contamination (excess oxygen being absorbed by negative plates).
- Computer-aided 99.994% pure heavy-duty lead calcium grid designs.
- Tank formed plates: guarantees evenly formed and capacity matched plates.
- Discover™ proprietary Vision Max® Paste Formula.
- Anchored plate groups to guard against vibration.
- Double insulating Micro porous glass fiber separators.
- Measured and Immobilized electrolyte.
- Vacuum filling and weighing processes.
- Advanced technology for efficient gas recombination of up to 99.9% and freedom from electrolyte maintenance.
- Wide range of operating temperatures (-40°F to 140°F) (-60°F to 160°F Gel).
- Low self discharge rates (Approx. 1%-3% monthly at 68.F – 77.F)
- High impact reinforced strength copolymer polypropylene cases and flat top designed covers that are rugged and vibration resistant.
- Thermally welded case to cover bonds that eliminate leakage.
- Copper and stainless steel alloy terminals and hardware.
- Multi-terminal options.
- Terminal protectors.
- Removable carry handles.
- Industry leading size and performance options.
- Classified as "NON-SPILLABLE BATTERY" Not restricted for Air (IATA/ICAO) Provision 67, Surface (DOT-CFR-HMR49) or Water (Classified as non-hazardous per IMDG amendment 27) transportation
- Can be used in any orientation – Upside down is not recommended – do not charged up side down!
- Compatible with sensitive electronic equipment.
- Quality Assurance processes with ISO (4400/992579), QS and TUV Certification EMC tested, CE, ETTS Germany (G4M19906-9202-E-16)
- Tellcordia and Bellcore compliant
- UL recognized and approved components (MH29050).



EVGC6A-A

Mechanical Characteristics

Industry Type No.	Volts	Standard (optional) Terminals	Dimensions in Inches (mm)				Approx. Weight in Lbs (Kgs)
			L in(mm)	W in(mm)	H in(mm)	TH in(mm)	
GC6	6	AM	10.2 (260)	7.1 (180)	10 (254)	10.8 (274)	66.1(30)

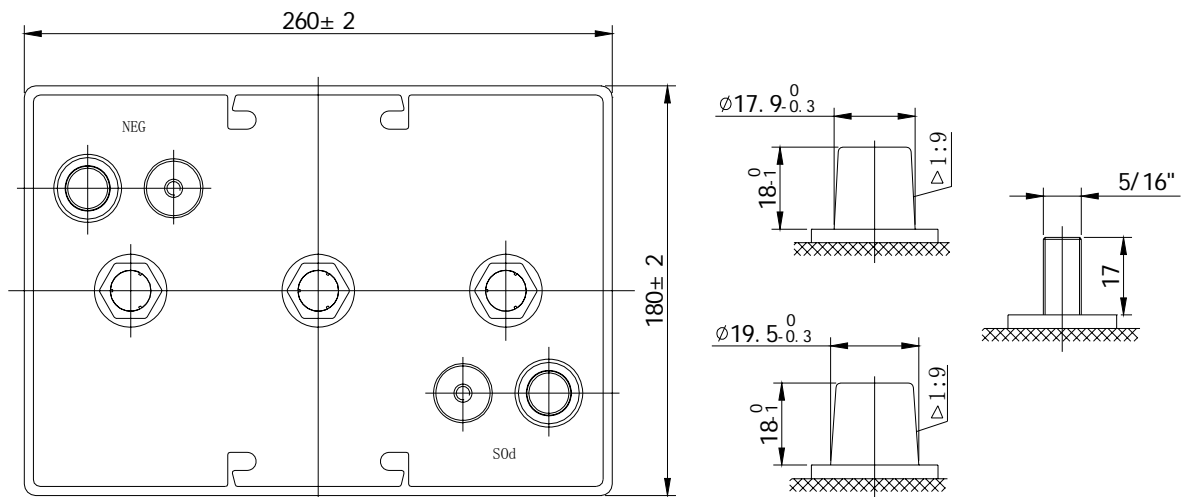
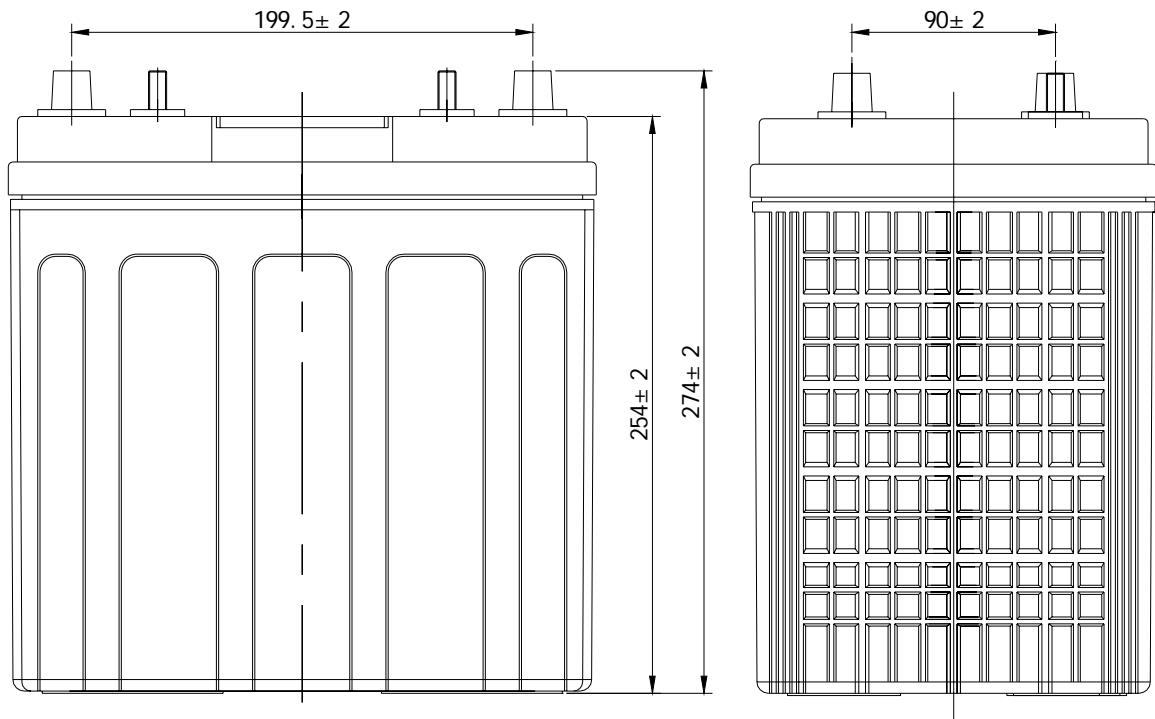



Electrical Specifications

Ampere Hour Capacity			Minutes of Discharge					R/C	Cranking Amps	
20HR	10HR	5HR	@25A	@56A	@75A	@85A	@100A	@25A	32°F / 0°C	0°F / -18°C
* - Performance averages after 15 cycles										
213	198	185	475	182	124	104	79	404	975	750

Constant current discharge ratings-amperes at 20°C (68°F)

End Point Volts/Cell	5min	10min	15min	30min	45min	1h	3h	5h	10h
1.60V	--	--	--	--	148	122	57.4	38	20.4
1.65V	--	--	--	--	145	121	56.9	37.7	20.2
1.70V	--	--	--	--	142	119	56.3	37.4	20.0
1.75V	--	--	--	--	139	117	55.7	37	19.8
1.80V	--	--	--	--	136	115	55.1	36.6	19.6

Constant power discharge ratings-watts per cell at 20°C (68°F)

End Point Volts/Cell	5min	10min	15min	30min	45min	1h	2h	3h	5h
1.60V	--	--	--	--	289	241	146	105	64.9
1.65V	--	--	--	--	285	238	145	104	64.4
1.70V	--	--	--	--	281	235	144	103	63.9
1.75V	--	--	--	--	276	232	142	102	63.4
1.80V	--	--	--	--	271	228	140	101	62.9

Internal resistance	Fully charged at 20°C: 2.6 mOhms		
Self discharge	<3% of capacity per month at 20°C		
Operating temperature range	Discharge	Charge	Storage
	-20~60°C	-10~60°C	-20~60°C
Max. discharge current (20°C)	1050A(5s)		

CHARGE METHODS: Constant voltage charging at 20°C (68°F)			
	Max. Charge current	Charge voltage	Temperature compensation
Standby use	0.3C _{10A}	6.80~6.90V	-10mV/°C
Cyclic use	0.3C _{10A}	7.20~7.35V	-15mV/°C

Charge / Discharge Tables & Graphs

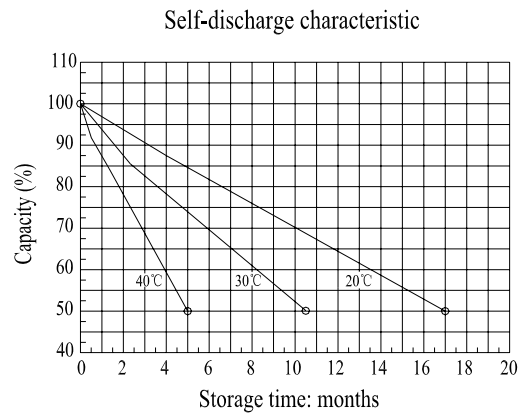
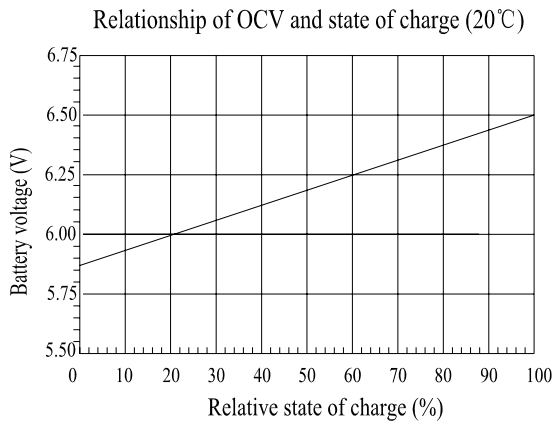
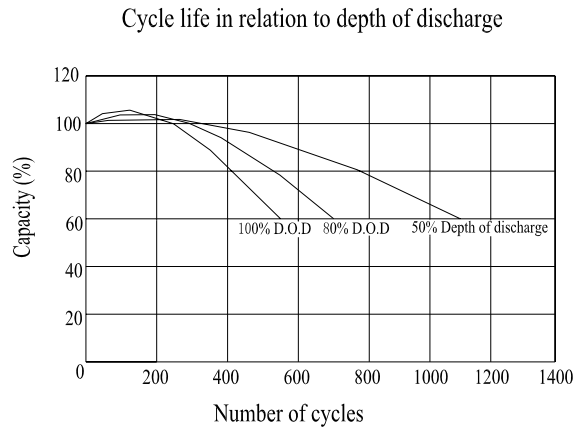
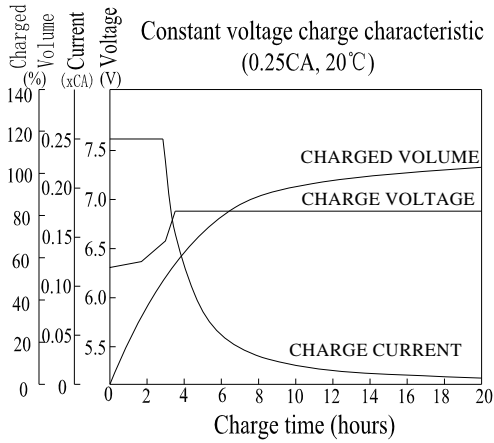

Relationship between charging voltage and temperature

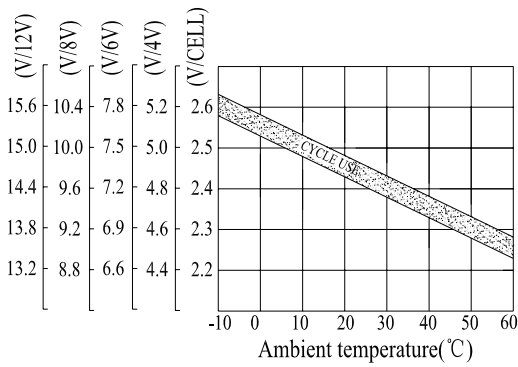

Temperature effects on capacity

